

DRIVE THE CHANGE



CORMIDI

C60
MINI TRACKED MACHINE



DRIVE THE CHANGE

MAXIMUM EFFICIENCY



Endless hours of testing and fine tuning made the C60 the best in its class for performance and reliability. We created a durable machine with maintenance cost close to none.

UNDERCARRIAGE



Our undercarriage is like no one. Our Cormidi R&D department put all its experience towards creating the best undercarriage available on the market.

SIMPLY INCREDIBLE



The Cormidi design lab created a machine that mixes industrial design with strength, power and easy to use

CORMIDI

C60
MINI TRACKED MACHINE



DRIVE THE CHANGE

STRENGTHS

ROCKING ROLLS



the machine's undercarriage, unique to the Cormidi line, has suspensions follow the terrain profile for increased stability and comfort.

HOOKS



4 Large and sturdy hooks to move the machine in total safety, plus 2 for towing.

SAFETY SUPPORTS



C60 has all approved and certified safety support, making it one of the most secure unit in the world.

LEVERS



the operators has a perfect access to all the controls and can keep all the parameters under control.

PARKING BRAKE



Mechanical parking and emergency brake.

DASHBOARD



Complete with horn, throttle, and 12V outlet.

ENGINE COMPARTMENT



the design of the engine compartment allows easy access to all the component for routine maintenance.

RADIATOR



The C60 has a powerful radiator with fan and thermostat to cool the hydraulic system.

CLOSABLE STAND



when the situation needs a shorter unit, the stand can be closed, otherwise it opens to let the operator in.

CORMIDI

C60

MINI TRACKED MACHINE



DRIVE THE CHANGE

THE BENCHMARK



with its 5 models and 20 possible version it can be tailored to answer anyone's need.

HEAVY DUTY



with increased safety, incredible performance and still easy to drive the C60 is at the top of its class

STURDY AND POWERFUL



Long lasting undercarriage, reduce need for maintenance, incredible power and reduced fuel consumption make the c60 an incredible unit.

CORMIDI

CMF
MULTI FUNCTION MACHINE



DRIVE THE CHANGE

VERSIONS



RIA	RI	AC	HI	HIAC

DIMENSIONS

	mm	in		mm	in		mm	in		mm	in		mm	in	
(A)	1677	66	(D)	115	4.5	(G)	1528	60.2	(L)	768	30.2	(O)	1675	65.9	
(B)	755	29.7	(E)	695	27.4	(H)	1135	44.7	(M)	722	28.4	(P)	2010	79.1	
(C)	1155	45.5	(F)	2229	87.7	(I)	740	29.1	(N)	1677	66	(Q)	2765	108.9	
													(R)	695	27.4

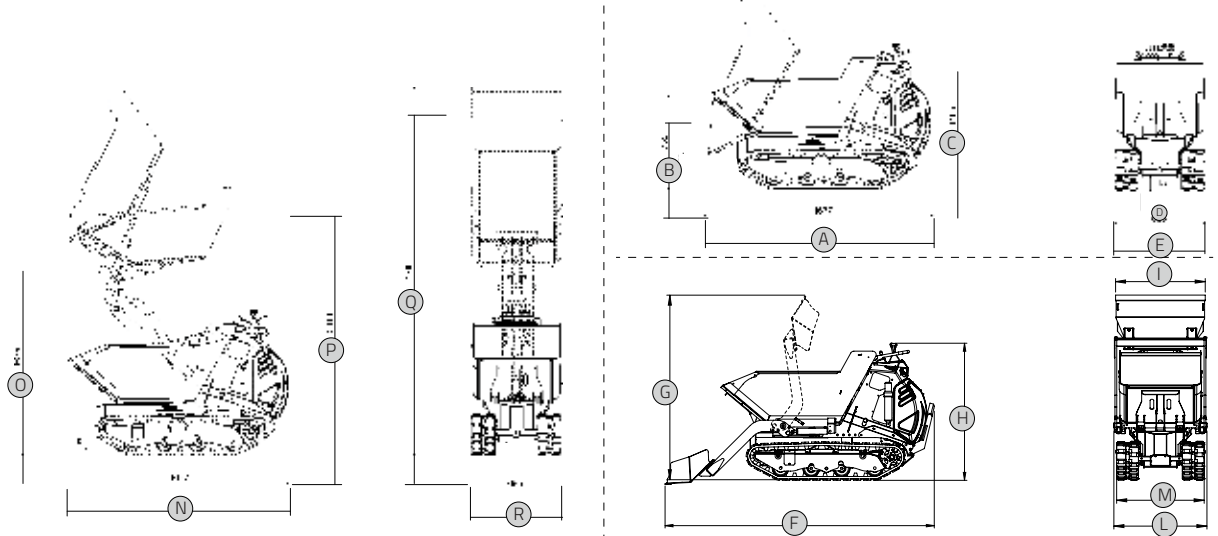

CAPACITY

BE-DE-BHE DHE-ACDHE-DEAC	 WATER 0,15 m ³ 0,2 yd ³	 STRUCK 0,22 m ³ 0,29 yd ³	 HEAPED SAE 0,28 m ³ 0,37 yd ³
RIA		 STRUCK 0,13 m ³ 0,17 yd ³	 HEAPED SAE 0,21 m ³ 0,27 yd ³

TECHNICAL DATA

	METRIC		U.S.		6.60	9.60
ENGINE						
Petrol	Honda GX 270 9 hp					●
Diesel	Yanmar LA 70 7.5 hp				●	
TRANSMISSION						
Type	Hydrostatic				●	●
Hydraulic pump	n°3 Gear pump				●	●
TRACKS						
Crawler width	180 mm	(7.1 in)			●	●
Rocking rollers	Yes				●	●
HYDRAULIC SYSTEM						
Hydraulic pump	Gear pump					
Flow	1x16 l/min	(1x4.2 gpm)			●	●
max pressure	170 bar	(2466 psi)			●	●
PERFORMANCE AND DIMENSIONS						
Max. travel speed	approx 0-3.6 Km/h		(0-2.3 mph)		●	●
Operative weight	600 kg		(1320 LB)		●	●
Weight	BE 463 kg /1021 lb	BHE 552 kg /1217 lb	ACBE 506 kg /1116 lb	ACBHE 628 kg /1385 lb	●	
	DE 476 kg /1049 lb	DHE 567 kg / 1250 Lb	DEAC 520 kg / 1146 Lb	ACDHE 638 kg / 1407 Lb	●	
Vessel contents	0,25 m ³ - 0,33 yd ³				●	●
Parking brake	Yes				●	●

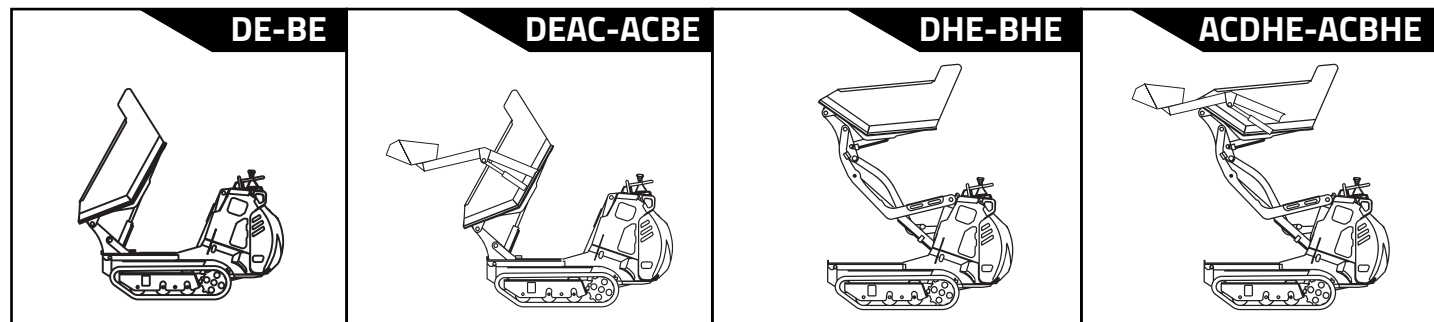



DRIVE THE CHANGE

WWW.CORMIDI.COM



Please note: The machines and accessories depicted in brochures and catalogues can vary from version to version, therefore please consult your distributor for a description of standard accessories and options available for each model. Cormidi reserves the right to change or to modify the specification of the machines without warning. The photos in catalogues and brochures represent the Cormidi machines in production at time of printing. However, newer and upgraded models may look different to the photos shown in this catalogue or brochure.

 Via Fonte, 342 Roccadaspide
(SA) Italy
ph. +39 0828 943688
fax +39 0828 943963

CORMIDI

25 Broad St, Norwalk 
CT 06851, USA
ph. +1 203-846-6120
art@cormidiusa.com