

872G / GP

6WD Motor Grader



JOHN DEERE





MAKE GRADE AND MOVE AHEAD IN A BIG WAY

For almost six decades, John Deere motor graders have been building a reputation for outstanding control and effortless grading precision. Thanks to the best ideas of customers like you, we've achieved a legacy of industry firsts. Productivity boosters like exclusive automation features on Grade Pro (GP) models. Jobsite-proven dual-joystick controls. And wide-ranging grade-control options from cross slope to fully integrated SmartGrade models. With a tall mainframe that smoothly shoulders large loads and clears obstacles, the 872G/GP's exceptional balance, optimized performance specs, and reliable capability can help you take grading performance to the next level and your operation in a reimagined new direction.

872G/GP 6WD MOTOR GRADER

FEATURES

Precision matters

On six-wheel-drive models precision mode allows the operator to manage a consistent speed via dial switch instead of inching pedal, maximizing productivity in all soil conditions. Six-wheel drive is adjustable on the fly to capably traverse difficult jobsites.

Power that checks and balances

Increased engine horsepower, torque, and blade pull over earlier models produce generous power and lugging ability, to deliver more power to the ground, easily pull through tough spots, or tackle steep hills. John Deere motor graders are designed with optimal weight distribution over each axle, for outstanding balance and grading performance.

Freedom of choice

Our G-Series Graders let you choose how work gets done. On our GP models, opt for fatigue-minimizing dual-joystick controls, choose state-of-the-art electrohydraulic (EH) fingertip armrest controls, or have the best of both worlds with a field kit that allows you to easily swap between the two. Our G models offer conventional lever-operated controls. And based on customer feedback, all models still have a steering wheel.

Count on cross slope

Standard on all GP models, cross slope maintains slopes by automatically adjusting one side of the blade while the operator controls the other. Cross slope can also be operated in "manual mode" as a slope meter. Automated cross slope simplifies holding a consistent slope by reducing operation to a single lever. Both dual-joystick controls and fingertip armrest controls come equipped with cross slope and can be easily upgraded to 3D SmartGrade.

Unlimited grade control

Industry-first John Deere SmartGrade Motor Graders are fully integrated and calibrated from the factory, arriving at your jobsite ready to work. In-cylinder position sensing allows the machine to stay on grade no matter what blade pitch, articulation angle, or circle offset you're running, without the limitations imposed by masted systems.



CONFIGURABLE
CONTROL
OPTIONS

+



FACTORY EQUIPPED
WITH OPTIONAL
SMARTGRADE™

Picture yourself here

All-around visibility is virtually unobstructed, with a clear view to the heel and toe as well as behind the moldboard. You can also see the area beneath the front axle, for increased awareness of oncoming obstacles. LCD hi-vis monitor provides intuitive, push-button access to vital machine data displayed via simple, easy-to-navigate icons and menus. High-resolution rearview camera with dedicated in-cab monitor comes standard.

Uptime is everything

All daily service points, including fuel and diesel exhaust fluid (DEF), are grouped on the left side of the machine for convenient ground-level access. On the right, periodic-service points including the engine oil, fuel, hydraulic, transmission, and differential filter bank are within easy reach. Cooling package minus stacked coolers plus hinged swing-out fan simplifies core cleanout. Variable-speed hydraulically driven fan[†] runs only as fast or as often as needed, to conserve power and fuel while reducing noise.

[†]Standard for EPA Final Tier 4/EU Stage V; optional for EPA Tier 3/EU Stage IIIA and EPA Tier 2/EU Stage II.

Premium productivity

Featuring a fully sealed bearing and pinion that run smoother and quieter, the industry-leading design of the optional premium circle reduces operating costs while delivering 40-percent more torque and 15-percent more speed than a traditional circle. The premium circle eliminates having to compensate for wear in the circle and improves accuracy when using a grade-control system — especially with John Deere SmartGrade. And greasing intervals of only four zerks every 500 hours make the premium circle essentially maintenance free. Durable dual-input circle is also available.

Connected machines

John Deere construction equipment comes with in-base connectivity — free from subscriptions or annual renewals. Analyze critical machine data, track utilization, review diagnostic alerts, and more from **the John Deere Operations Center™**. The Operations Center also enables John Deere Connected Support™, which uses data from thousands of connected machines to proactively address issues before they arise. With your approval, your dealer can also remotely monitor machine health, diagnose problems, and even update machine software without a trip to the jobsite.*

*Availability varies by region and product. Options not available in every country.



**INTUITIVE
AUTOMATION SUITE**
STREAMLINES MACHINE CONTROL





872G/GP 6WD MOTOR GRADER

PUT INTELLIGENCE TO WORK

With **Automation Suite** including industry-exclusive Auto-Gain for Cross Slope, Auto-Pass, and Auto-Shift PLUS, it's push-button easy to set yourself apart from your competition. Our automation advantages for all Grade Pro (GP) models are also available as field kits on SmartGrade models:

- **Auto-Shift PLUS** — also available on all G-Series models — allows operators to work without using the inching pedal.
- **Auto-Gain for Cross Slope** automatically adjusts gain settings based on ground speed to maximize performance.
- **Auto-Articulation** lets the operator increase the maneuverability of coordinated steering and articulation while using only the joystick-steering function to steer and operate other necessary functions without manually articulating the machine.
- **Machine-Damage Avoidance** eliminates the risk of blade damage to machine structures during any operation.
- **Auto-Pass** makes grading easy by automatically placing the blade on the ground and activating the grade-control system (when equipped) at the start of the pass, then automatically raising and resetting the blade at the end of it.
- Use **Blade Flip** to automatically mirror the circle to a preset angle.
- Easily prepare the machine for transport with **Machine Presets**. Stow the blade and ripper, turn on the lights including the hazards, and enable Auto-Shift with one push-button press.

872G/GP

6WD MOTOR GRADER SPECIFICATIONS

Engine		872G/GP	
Manufacturer and Model	John Deere PowerTech™ PSS 9.0L	John Deere PowerTech™ Plus 9.0L	John Deere PowerTech™ 9.0L
Non-Road Emission Standard	EPA Final Tier 4/EU Stage V	EPA Tier 3/EU Stage IIIA	EPA Tier 2/EU Stage II
Cylinders	6	6	6
Displacement	9.0L (548 cu. in.)	9.0L (548 cu. in.)	9.0L (548 cu. in.)
Net Engine Power			
Gear 1	183 kW (245 hp)	179 kW (240 hp)	179 kW (240 hp)
Gear 2	190 kW (255 hp)	187 kW (250 hp)	187 kW (250 hp)
Gear 3	201 kW (270 hp)	194 kW (260 hp)	194 kW (260 hp)
Gear 4	205 kW (275 hp)	198 kW (265 hp)	198 kW (265 hp)
Gear 5	212 kW (285 hp)	201 kW (270 hp)	201 kW (270 hp)
Gear 6	220 kW (295 hp)	209 kW (280 hp)	209 kW (280 hp)
Gear 7	224 kW (300 hp)	209 kW (280 hp)	209 kW (280 hp)
Gear 8	224 kW (300 hp)*	209 kW (280 hp)*	209 kW (280 hp)*
Net Peak Torque	1472 Nm (1,086 lb.-ft.)	1330 Nm (981 lb.-ft.)	1330 Nm (981 lb.-ft.)
Net Torque Rise	46%	48%	48%
Aspiration	Series turbocharged, charge-air cooled	Turbocharged, charge-air cooled	Turbocharged, charge-air cooled
Lubrication	Full-flow spin-on filter and integral cooler	Full-flow spin-on filter and integral cooler	Full-flow spin-on filter and integral cooler
Air Cleaner With Restriction Indicator	Dual element, dry	Dual element, dry	Dual element, dry
*6WD not available.			
Cooling			
Engine Coolant, Extended Life, Rating	-37 deg. C (-34 deg. F)		
Powertrain			
6-Wheel Drive	Automatic dual-path hydrostatic drive; increases tractive effort and front-end control; includes separate left and right systems with variable-displacement pumps, axial-piston wheel motors, and freewheel at transport speeds; operator-selectable 15-position rotary aggressiveness control and inching capability down to 0 mph; precision mode (propelled by front wheels only)		
Effective Gears	1-7 forward and reverse		
Precision Mode			
Effective Gears	1-3 forward only		
Operating Speeds	0.4-8.0 km/h (0.25-5.0 mph)		
Hydrostatic Pumps (2 each)	60 cm ³ (3.7 cu. in.)		
Wheel Motors	60 cm ³ (3.7 cu. in.)		
Final Reduction	38.7:1		
Transmission	Direct-drive John Deere PowerShift Plus™, modulated shift-on-the-go, Event-Based Shifting (EBS), inching pedal; independent transmission reservoir with separate filtration and cooling system with 121-L/min. (32 gpm) gear pump		
Gears			
Forward	8		
Reverse	8		
Maximum Travel Speeds	<i>No tire slip at 2,180 rpm, 17.5-R25 tires</i>		<i>No tire slip at 2,180 rpm, 17.5-R25 tires</i>
Gear 1	4.0 km/h (2.5 mph)	Gear 5	16.7 km/h (10.4 mph)
Gear 2	5.6 km/h (3.5 mph)	Gear 6	23.2 km/h (14.5 mph)
Gear 3	7.9 km/h (4.9 mph)	Gear 7	32.1 km/h (20.0 mph)
Gear 4	10.9 km/h (6.8 mph)	Gear 8	45.0 km/h (28.0 mph)
Front Axle	Heavy-duty welded fabrication		
Oscillation (total)	32 deg.		
Wheel Lean Angle (each direction)	20 deg.		
Differentials	Spiral bevel; hydraulically actuated, clutch type can be applied on-the-go; selectable manual or automatic differential lock		
Steering (all models include steering wheel)	All-hydraulic power-frame articulation for maneuverability and productivity; crab steering reduces side drift, positions tandems on firm ground, and increases side-slope stability; return-to-straight control included in Grade Pro (GP) option		
Turning Radius (front steer and articulation)	7.21 m (284 in.) (23 ft. 8 in.)		
Articulation (both right and left)	22 deg.		
Final Drives	Inboard-mounted planetary sealed in cooled, filtered oil		
Brakes	Foot-controlled, hydraulically operated, multiple wet-disc brakes sealed in pressurized, cooled, filtered oil; both independent systems effective on all 4 tandem wheels		
Primary and Secondary Brakes	Hydraulically actuated, inboard of tandem pivot, self-adjusting, sealed in cooled and filtered oil, multi-disc (ISO 3450)		
Parking Brake	Automatically spring applied, hydraulically released, oil cooled, self-adjusting (ISO 3450)		

While general information, pictures, and descriptions are provided, some illustrations and text may include product options and accessories NOT AVAILABLE in all regions, and in some countries products and accessories may require modifications or additions to ensure compliance with the local regulations of those countries.

Hydraulics		872G/GP
Type	Closed-center, pressure-compensated load-sensing (PCLS), variable-displacement piston pump	
Maximum Pump Flow	218 L/min. (57.5 gpm)	
Maximum System Pressure	18 961 kPa (2,750 psi)	
Pump Displacement	90 cm ³ (5.5 cu. in.)	
Blade Function		
All-hydraulic, industry-standard lever placement of blade-function controls; includes float position; 7 discrete saddle positions		
Blade Range		
Lift Above Ground	452 mm (17.8 in.)	
Blade Side Shift (right or left)	683 mm (26.9 in.)	
Pitch at Ground Line		
Forward	42 deg.	
Back	5 deg.	
Shoulder Reach Outside Wheels (frame straight, right or left)	2329 mm (91.7 in.) (7 ft. 8 in.)	
Bank Cut Angle (right or left)	90 deg.	
Blade Pull		
At Maximum Operating Weight	22 453 kg (49,500 lb.)	
Electrical		
Solid-state load center and sealed-switch module	<i>EPA Final Tier 4/EU Stage V</i>	<i>EPA Tier 3/EU Stage IIIA and EPA Tier 2/EU Stage II</i>
Voltage	24 volt	24 volt
Number of Batteries	2	2
Battery Capacity	1,400 CCA	1,400 CCA
Reserve Capacity	440 min.	440 min.
Amp-Hour Rating	224 amp-hour	224 amp-hour
Alternator Rating		
Base	130 amp	100 amp
Optional	200 amp	130 amp
Lights	Driving lights; 2 high- and 2 low-beam halogen headlights; front and rear LED turn signals and marker lights; LED brake and hazard warning lights	
Mainframe		
Type	Welded box construction	
Width (minimum)	307 mm (12.1 in.)	
Height (minimum)	307 mm (12.1 in.)	
Thickness		
Side	16 mm (0.63 in.)	
Top and Bottom Plate	30 mm (1.17 in.)	
Modulus		
Minimum Vertical Section	1770 cm ³ (108 cu. in.)	
Average Vertical Section at Saddle	2635 cm ³ (161 cu. in.)	
Draft Frame (drawbar)		
Welded box construction machined for flatness with double ball-and-socket pivot connection		
Circle		
Welded construction, heat-treated, machined for flatness		
	<i>Standard Circle</i>	<i>Premium Circle</i>
Circle Diameter	1524 mm (60 in.)	1524 mm (60 in.)
Rotation	360 deg.	360 deg.
Surface	Quick-change bronze or nylon wear inserts	Sealed and lubricated roller element slewing bearing
Pinion/Ring-Gear Connection	Adjustable backlash and open for serviceability	No adjustment; fully sealed and lubricated
Drive	Hydraulic motor and worm gear with positive lock	Hydraulic motor and worm gear with positive lock
Slip Clutch	Option	Standard
Circle Side Shift (right and left)	787 mm (31 in.)	787 mm (31 in.)
Moldboard		
High-strength, pre-stressed for higher strength, wear-resistant, high-carbon steel and reversible end bits; blade side-shift wear system includes quick-change replaceable wear inserts and quick-adjust jackscrew system		
Base Length	4.27 m (168 in.) (14 ft. 0 in.)	
Height (measured along arc, including cutting edge)	686 mm (27 in.)	
Thickness	25 mm (1 in.)	

While general information, pictures, and descriptions are provided, some illustrations and text may include product options and accessories NOT AVAILABLE in all regions, and in some countries products and accessories may require modifications or additions to ensure compliance with the local regulations of those countries.

872G/GP

6WD MOTOR GRADER SPECIFICATIONS (continued)

Cutting Edge		872G/GP	
Dura-Max™ through-hardened steel edge			
Thickness	19 mm (0.75 in.)		
Width	203 mm (8 in.)		
Scarifiers			
	<i>Front</i>	<i>Mid-mount</i>	
Type	V-type toolbar with 2-pitch positions and hydraulic float	Radial linkage, with NeverGrease™ pin joints	
Width of Cut	1.20 m (48 in.) (4 ft. 0 in.)	1.19 m (46.7 in.) (3 ft. 11 in.)	
Number of Shanks/Teeth	5 (maximum capacity 9)	11	
Lift Above Ground	589 mm (23.2 in.)	335 mm (13.2 in.)	
Maximum Depth	335 mm (13.2 in.)	325 mm (12.8 in.)	
Shank			
Spacing	146 mm (5.75 in.)	117 mm (4.6 in.)	
Size	25 x 76 mm (1 x 3 in.)	25 x 76 mm (1 x 3 in.)	
Front Lift Group (Balderson-style)			
Parallel linkage, mechanical pins, and hydraulic float			
Lift			
Above Ground (top of tube)	1864 mm (73.4 in.)		
Range	988 mm (38.9 in.)		
Rear Ripper/Scarifier			
Parallel linkage, with NeverGrease pin joints, hydraulic float, and integrated hitch			
	<i>Ripper</i>	<i>Scarifier</i>	
Width of Cut	2.21 m (87.2 in.) (7 ft. 3 in.)	2.18 m (86 in.) (7 ft. 2 in.)	
Number of Shanks/Teeth	3 (maximum capacity 5)	None standard (maximum capacity 9)	
Lift Above Ground	602 mm (23.7 in.)	810 mm (31.9 in.)	
Maximum Depth	426 mm (16.8 in.)	323 mm (12.7 in.)	
Force			
Penetration	10 483 kg (23,110 lb.)	—	
Pry-Out	14 843 kg (32,724 lb.)	—	
Shank Size	61.5 x 133 mm (2.42 x 5.25 in.)	25 x 76 mm (1 x 3 in.)	
Operator Station			
Low-profile cab with ROPS (ISO 3471-2008) and FOPS (ISO 3449-2005)			
Tires/Wheels			
	<i>17.5R25 on 356-mm (14 in.) Rim</i>	<i>550/65R25 on 432-mm (17 in.) Rim</i>	<i>20.5R25 on 432-mm (17 in.) Rim</i>
Wheel Tread on Ground	2.16 m (85.0 in.)	2.21 m (87.0 in.)	2.32 m (92 in.)
Overall Width	2.64 m (104.0 in.)	2.82 m (111.0 in.)	2.80 m (110 in.)
Ground Clearance (front axle)	587 mm (23.1 in.)	612 mm (24.1 in.)	640 mm (25.2 in.)
Serviceability			
Refill Capacities	<i>EPA Final Tier 4/EU Stage V</i>	<i>EPA Tier 3/EU Stage IIIA and EPA Tier 2/EU Stage II</i>	
Fuel Tank	416.5 L (110 gal.)	416.5 L (110 gal.)	
Diesel Exhaust Fluid (DEF) Tank	22.5 L (6 gal.)	—	
Cooling System	55.0 L (14.5 gal.)	48.5 L (12.8 gal.)	
Engine Oil With Filter	28.4 L (7.5 gal.)	28.0 L (7.4 gal.)	
Transmission Fluid	23.5 L (6.2 gal.)	28.4 L (7.5 gal.)	
Differential Housing	38.0 L (10 gal.)	38.0 L (10 gal.)	
Tandem Housings (each)	74.0 L (19.5 gal.)	74.0 L (19.5 gal.)	
Circle Gearbox	5.7 L (1.5 gal.)	5.7 L (1.5 gal.)	
Hydraulic Reservoir	60.5 L (16 gal.)	53.0 L (14 gal.)	
Operating Weights			
With Full Fuel Tank, 4.27-m x 686-mm x 25-mm (14 ft. x 27 in. x 1 in.) Moldboard With 203-mm x 19-mm (8 in. x ¾ in.) Cutting Edges, 17.5R25 L2 Tires, and 79-kg (175 lb.) Operator			
	<i>EPA Final Tier 4/EU Stage V</i>	<i>EPA Tier 3/EU Stage IIIA and EPA Tier 2/EU Stage II</i>	
Front	5110 kg (11,266 lb.)	5119 kg (11,285 lb.)	
Rear	12 902 kg (28,444 lb.)	12 254 kg (27,015 lb.)	
Total	18 012 kg (39,710 lb.)	17 372 kg (38,300 lb.)	
Typical Operating Weight With Front Push Block, Rear Ripper/Scarifier, and Other Equipment			
Front	6516 kg (14,365 lb.)	6573 kg (14,490 lb.)	
Rear	15 084 kg (33,255 lb.)	14 152 kg (31,200 lb.)	
Total	21 600 kg (47,620 lb.)	20 725 kg (45,690 lb.)	
Maximum Operating Weight	24 948 kg (55,000 lb.)		24 948 kg (55,000 lb.)

While general information, pictures, and descriptions are provided, some illustrations and text may include product options and accessories NOT AVAILABLE in all regions, and in some countries products and accessories may require modifications or additions to ensure compliance with the local regulations of those countries.

Option Weights 872G/GP

Moldboards With Through-Hardened Dura-Max Cutting Edge	
3.96 m x 686 mm x 25 mm (13 ft. x 27 in. x 1 in.)	-72 kg (-159 lb.)
With 203-mm x 19-mm (8 in. x ¾ in.) Cutting Edge and 16-mm (⅝ in.) Hardware	
4.27 m x 686 mm x 25 mm (14 ft. x 27 in. x 1 in.)	0 kg (0 lb.)
With 203-mm x 19-mm (8 in. x ¾ in.) Cutting Edge and 16-mm (⅝ in.) Hardware	
4.27 m x 686 mm x 25 mm (14 ft. x 27 in. x 1 in.)	9.5 kg (21 lb.)
With 203-mm x 19-mm (8 in. x ¾ in.) Cutting Edge and 19-mm (¾ in.) Hardware	
4.88 m x 686 mm x 25 mm (16 ft. x 27 in. x 1 in.)	137 kg (302 lb.)
With 203-mm x 19-mm (8 in. x ¾ in.) Cutting Edge and 19-mm (¾ in.) Hardware	
Extensions, 610 mm (2 ft.) (right or left)	
For Use With 686-mm (27 in.) Moldboards	120 kg (265 lb.)
Overlay End Bits, Reversible (one pair)	
For 152-mm (6 in.) Cutting Edge	19.5 kg (43 lb.)
For 203-mm (8 in.) Cutting Edge	23 kg (51 lb.)
Heavy-Duty Dual-Input Circle-Drive Gearbox	14 kg (31 lb.)
Circle-Drive Slip Clutch	9 kg (20 lb.)
Circle	
Standard	0 kg (0 lb.)
Premium	255 kg (562 lb.)
Moldboard Impact-Absorption System	43 kg (95 lb.)
Ripper/Scarifier, Rear Mounted With Hitch and Ripper Shanks (3)	1139 kg (2,510 lb.)
Scarifier Shanks With Teeth (9 for rear ripper/scarifier)	68 kg (150 lb.)
Ripper Shanks and Teeth (2)	63 kg (139 lb.)
Rear Counterweight With Integral Rear Hitch	727 kg (1,603 lb.)
Rear Hitch	54.4 kg (120 lb.)
Push Block, Front	1338 kg (2,950 lb.)

Machine Dimensions

A Height to Top of Cab	3.18 m (10 ft. 5 in.)
A' Height to Top of Full-Height Cab	3.40 m (11 ft. 2 in.)
B Height to Top of Exhaust	3.13 m (10 ft. 3 in.)
C Height to Top of Blade-Lift Cylinders	3.05 m (10 ft. 0 in.)
D Tandem Axle Spacing	1.54 m (5 ft. 1 in.)
E Blade Base	2.53 m (8 ft. 4 in.)

Option Weights (continued) 872G/GP

Scarifier	
Front Mount With Teeth (5)	831 kg (1,833 lb.)
Mid-Mount With Teeth (11)	1481 kg (3,265 lb.)
Front Lift Group (Balderson-style)	763 kg (1,682 lb.)
Tires	
17.5-R25, Radial, L2 General Purpose	0 kg (0 lb.)
17.5-R25, Radial, G2/L2 Snow	43.5 kg (96 lb.)
17.5-R25, Radial, G3/L3 General Purpose	90 kg (198 lb.)
550/65R25 XLD70 G3/L3 Radial, General Purpose	444 kg (978 lb.)
20.5-R25, Radial, L2 Snow	414 kg (913 lb.)
20.5-R25, Radial, L2 General Purpose	474 kg (1,045 lb.)
Multi-Piece Rims	
356 mm x 635 mm (14 in. x 25 in.)	0 kg (0 lb.)
432 mm x 635 mm (17 in. x 25 in.)	46 kg (102 lb.)
Fenders	
Front	99 kg (218 lb.)
Rear	141 kg (310 lb.)
Low Cab With Opening Front and Side Windows	14.5 kg (32 lb.)
Premium Air-Suspension, Heated Seat With Adjustable Arm- and Headrests	13 kg (28 lb.)
Coolant Heater	4 kg (9 lb.)
Quick Service	11 kg (24 lb.)
Sound-Absorption Package (machines equipped with Tier 3/Stage IIIA and Tier 2/Stage II engines only)	14 kg (31 lb.)
Secondary Steering	26 kg (58 lb.)
Beacon Bracket	8 kg (18 lb.)
Fire Extinguisher	14.5 kg (32 lb.)
Lighting Packages	
10 Halogen Lights	4.5 kg (10 lb.)
18 Halogen Lights	8 kg (18 lb.)
18 LED Lights	7 kg (16 lb.)
High-Front Light Bar for Snowplowing	20 kg (44 lb.)
Auxiliary Hydraulic Control Valve Section and Controls	7 kg (15 lb.)
Hydraulics for Front-Mounted Equipment	9 kg (19 lb.)

Machine Dimensions (continued)

F Wheelbase	6.16 m (20 ft. 3 in.)
G Overall Length	8.89 m (29 ft. 2 in.)
H Overall Length With Scarifier	9.69 m (31 ft. 9 in.)
I Overall Length With Push Block and Ripper	9.99 m (32 ft. 9 in.)
II Overall Length With Scarifier and Ripper	10.59 m (34 ft. 9 in.)

For Overall Width see Tires/Wheels on page 8.

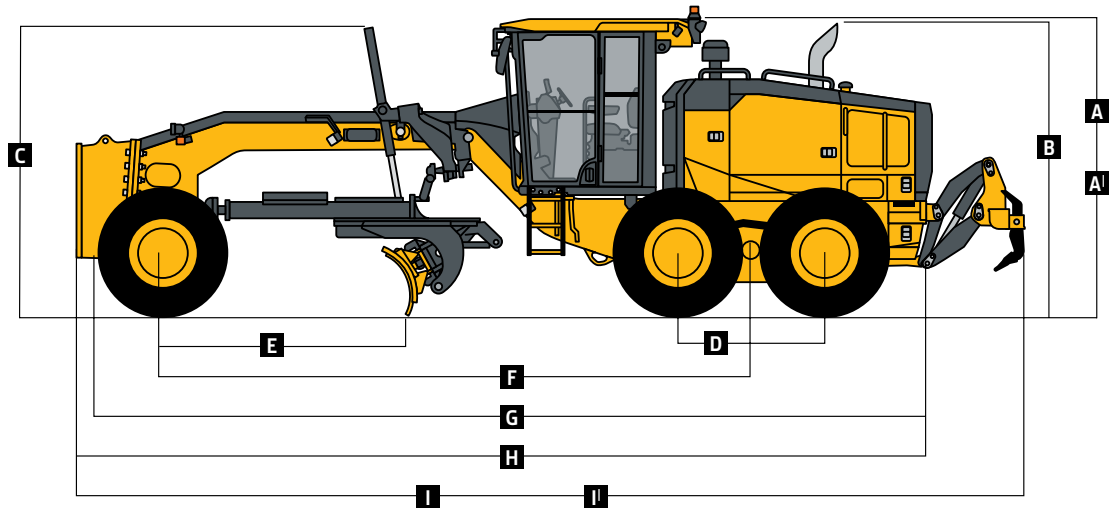

While general information, pictures, and descriptions are provided, some illustrations and text may include product options and accessories NOT AVAILABLE in all regions, and in some countries products and accessories may require modifications or additions to ensure compliance with the local regulations of those countries.

Additional equipment

Key: ● Standard ▲ Optional or special See your John Deere dealer for further information.

872G/GP Operator's Station

- Low-profile ROPS/FOPS cab with HVAC (ROPS ISO 3471 / FOPS SAE 3449 Level II)
- ▲ Low-profile ROPS/FOPS cab utilizing laminated glass with fixed lower front and side opening windows
- ▲ Opening front and side windows (standard with Grade Pro)
- Keyless start with multiple security modes
- Fabric air-suspension seat with armrests and headrest
- ▲ Premium heated, leather/fabric, high-wide-back, air-suspension seat with armrests (standard with Grade Pro)
- Sealed-switch module with function indicators
- Electric rear-window defroster
- Upper front windshield washers with intermittent wipers
- Upper rear windshield washers with intermittent wipers
- ▲ Lower front intermittent wiper and washer
- ▲ Powered cab precleaner
- ▲ Decelerator pedal
- ▲ Flip-down, right- and/or left-hand cab beacon with bracket
- Cab prewired for beacon, radio, and auxiliary circuit
- Front window sun visor
- ▲ Retractable rear sunshade
- Rearview mirrors, exterior (2) (SAE J985)
- ▲ Heated exterior mirrors (2) (SAE J985)
- ▲ Fire extinguisher
- High-resolution rear camera with dedicated in-cab monitor (in some markets)
- ▲ High-resolution front/rear-camera combination with dedicated in-cab monitor
- Retractable seat belt, 76 mm (3 in.) (SAE 386)
- ▲ AM/FM radio with auxiliary and Weather Band (WB)
- ▲ AM/FM radio with Bluetooth®, auxiliary, and WB ready
- Push-button-activated cruise control

872G/GP Electrical

- 100-amp alternator (Tier 3/Stage IIIA and Tier 2/Stage II)
- 130-amp alternator (FT4/Stage V [optional for Tier 3/Stage IIIA and Tier 2/Stage II])
- ▲ 200-amp alternator (FT4/Stage V)
- Batteries (2), 1,400 CCA with 440-min. reserve capacity
- Left-hand engine compartment service-check light
- ▲ Right-hand engine compartment service-check light
- Transporting lights (4 halogen)
- ▲ Grading lights (10 halogen lights)
- ▲ Deluxe grading lights (18 halogen lights)
- ▲ Premium grading lights (18 LED lights)
- ▲ Tall front snowplow light bar
- Multifunction/multi-language diagnostic LCD color monitor
- Reverse warning alarm (SAE J994)
- LED brake and turn lights

Moldboard

Patented pre-stressed, high strength, wear resistant:

- ▲ 3.96 m x 686 mm x 25 mm (13 ft. x 27 in. x 1 in.)
- 4.27 m x 686 mm x 25 mm (14 ft. x 27 in. x 1 in.)
- ▲ 4.88 m x 686 mm x 25 mm (16 ft. x 27 in. x 1 in.)
- Quick-change and jackscrew-adjustable moldboard side-shift extreme-duty wear inserts
- ▲ 610-mm (24 in.) left- or right-hand extensions for 686-mm (27 in.) moldboard
- ▲ Reversible overlay endbits

Overall Vehicle

- JDLink™ wireless communication system (available in specific countries; see your dealer for details)
- Ground-level fuel and diesel exhaust fluid (DEF) filling
- Fluid-sampling ports for engine oil and coolant, hydraulic oil, and axle and transmission fluids
- Vandal-protection locking for: Cab doors / Top tank radiator-access door / Engine coolant surge tank / Hydraulic reservoir cap / Battery-disconnect switch / Ground-level electrical master disconnect switch / Fuel-tank door and cap / Toolbox

While general information, pictures, and descriptions are provided, some illustrations and text may include product options and accessories NOT AVAILABLE in all regions, and in some countries products and accessories may require modifications or additions to ensure compliance with the local regulations of those countries.

Net engine power is with standard equipment including air cleaner, exhaust system, alternator, and cooling fan at test conditions specified per ISO 9249. No derating is required up to 3050-m (10,000 ft.) altitude. Specifications and design subject to change without notice. Wherever applicable, specifications are in accordance with SAE standards. Except where otherwise noted, these specifications are based on a unit with standard equipment; 17.5 R 635-mm (25 in.) L2, Radial tires; and 4.27-m x 688-mm x 25-mm (14 ft. x 27 in. x 1 in.) high-strength, wear-resistant moldboards with 16-mm x 152-mm (0.63 in. x 6 in.) Dura-Max through-hardened-steel cutting edges. Weights include lubricants, coolants, full fuel tank, and 79-kg (175 lb.) operator.

Additional equipment *(continued)*

Key: ● Standard ▲ Optional or special See your John Deere dealer for further information.

872G/GP Overall Vehicle *(continued)*

- Environmental drains with hoses for engine, transmission, hydraulic, differential fluids, and engine coolant
- Hydraulically driven cool-on-demand reversing fan (FT4/Stage V [optional for Tier 3/Stage IIIA and Tier 2/Stage II])
- Banked easy-access vertical spin-on filters for hydraulic, transmission, and axle fluids
- Engine rotary ejector precleaner
- Automatic differential lock
- Engine-stall prevention and auto shutdown
- ▲ Adjustable rotary engine precleaner (FT4/Stage V)
- Heavy-duty air cleaner (FT4/Stage V)
- Heavy-duty dual-input circle drive without slip clutch
- ▲ Heavy-duty dual-input circle drive with slip clutch
- ▲ Premium circle
- ▲ Auto-Shift transmission
- ▲ Auto-Shift PLUS transmission
- ▲ Blade-impact-absorption system
- ▲ Front and/or rear wheel fenders
- ▲ Quick-service bank for transmission, hydraulic, engine oil, and engine coolant fluid changes
- ▲ Secondary steering
- ▲ Sound-absorption package (Tier 3/Stage IIIA and Tier 2/Stage II)
- ▲ Wheel chocks

Automation (standard on SmartGrade™ models, optional on Grade Pro [GP] models)

- ▲ Automation Suite
- ▲ Auto-Articulation
- ▲ Auto-Gain for Cross Slope
- ▲ Auto-Pass
- ▲ Blade Flip
- ▲ Machine Presets
- ▲ Machine-Damage Avoidance

872G/GP Front Attachments

- ▲ Front push block
- ▲ V-type front scarifier with float position, 5 shanks
- ▲ Mid-mount scarifier with float position, 11 shanks
- ▲ Front Balderson-style lift group with float position
- ▲ Front-mounted dozer blades

Rear Attachments

- Full bottom guard with access panel and side guards for rear vehicle protection
- ▲ Rear-mounted ripper/scarifier combination with rear hitch and pin, 3 ripper shanks
- ▲ Rear counterweight with rear hitch and pin
- ▲ Rear hitch and pin
- ▲ Extra scarifier shanks (9) with teeth for rear ripper scarifier
- ▲ Extra ripper shanks (2) with teeth for rear ripper/scarifier

Grade Pro (GP) Option

- Low-profile GP cab with opening lower front and side windows
- ▲ Low-profile GP cab utilizing laminated glass with fixed lower front and side opening windows
- Premium heated, leather/fabric, high-wide-back, air-suspension seat with armrests
- ▲ Dual-joystick controls
- ▲ Fingertip armrest-mounted controls including steering lever
- Steering wheel
- Cross slope
- Return to straight

Grade Control

- ▲ SmartGrade available on GP models
- ▲ Mast mounts
- ▲ Topcon ready available on G and GP models
- ▲ Trimble ready available on G and GP models

While general information, pictures, and descriptions are provided, some illustrations and text may include product options and accessories NOT AVAILABLE in all regions, and in some countries products and accessories may require modifications or additions to ensure compliance with the local regulations of those countries.

Net engine power is with standard equipment including air cleaner, exhaust system, alternator, and cooling fan at test conditions specified per ISO 9249.

No derating is required up to 3050-m (10,000 ft.) altitude. Specifications and design subject to change without notice. Wherever applicable, specifications are in accordance with SAE standards. Except where otherwise noted, these specifications are based on a unit with standard equipment;

17.5 R 635-mm (25 in.) L2, Radial tires; and 4.27-m x 688-mm x 25-mm (14 ft. x 27 in. x 1 in.) high-strength, wear-resistant moldboards with 16-mm x 152-mm (0.63 in. x 6 in.) Dura-Max through-hardened-steel cutting edges. Weights include lubricants, coolants, full fuel tank, and

79-kg (175 lb.) operator.



DKAGDR872 (24-10)



JOHN DEERE