

# KOMATSU

**GD555-5**

**HORSEPOWER**

Gross: 146kW 196 HP @ 2000 rpm

Net: 144kW 193 HP @ 2000 rpm

**OPERATING WEIGHT**

18120 kg 39947 lb

**BLADE LENGTH**

3.71 m 12 ft

**GD655-5**

**HORSEPOWER**

Gross: 165kW 221 HP @ 2100 rpm

Net: 163kW 218 HP @ 2100 rpm

**OPERATING WEIGHT**

18520 kg 40744 lb

**BLADE LENGTH**

4.32 m 14 ft

## GD555-5 & GD655-5

Australian and New Zealand Version

**ecot3**

**GD**

**555-5 & 655-5**

**MOTOR GRADER**



*Photo may include optional equipment*

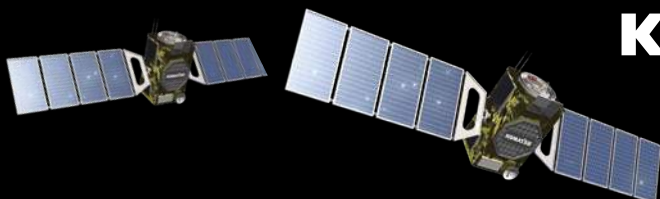

**KOMTRAX**



# WALK-AROUND

## Komatsu "Dantotsu" Feature (Unique & Unrivalled)

### Dual Mode Transmission with NON Stall Function

- » Operator Can Select
- » Torque Converter Drive Mode
- » Direct Drive Mode

### Fuel Economy

### Dual Mode Power/Fuel Consumption

- » Operator Can Select
- » Power Mode
- » Economy Mode

### "Save Money"

### Excessive Idle Shut Down (Programmable)

- » Decrease wasteful Idle Time
- » Reduce Fuel Consumption
- » Increased Uptime
- » Increased Time Between Services

## Excellent Operator Environment

- » Exceptional visibility by Hexangular cabin with Front Y Shaped Pillar
- » Heavy Duty High Performance Air Conditioning System
- » Low Operating Noise (Internal External)
- » Top of the Range Air Suspension Seat
- » Large Lunch Box Storage Area

## KOMTRAX



Komatsu Satellite Monitoring System.

- » Komatsu Blade
- » Suspension System

which allows excellent vision  
Blade Lift Cylinder Accumulators  
(Standard fitment)



**Steering Cylinder Guards**  
(Standard fitment)

### (Optional) Topcon 2D System Five Cross Slope

Economically Expanded to "3D Hire Ready or Full 3D"  
Trimble or Leica 3D Machine Control can be installed  
in Lieu of Topcon at customer request.

**Excellent Performance**

- » *Environment friendly Komatsu SAAD6D107E-1 engine complies with EPA Tier3. EU stage 3A Emission. See page 4.*
- » *Smooth operation without the engine stalling at low speed and maximise productivity. See page 5.*
- » *Excellent blade controllability with multifunctional control valves with float and PCV (Pilot Check Valve). See page 6.*
- » *Aggressive moldboard angles are possible with a long wheel base. See page 6.*

**Steel Tropical Roof Kit with Rear Visor**

Australian Market only

**Roof Mounted LED Beacons with Guards**

**Turbo II Pre-Cleaner**  
(Standard Fitment)



**“Power On Demand”**

**Industry Leading**

- » *Komatsu Hydramind Hydraulic System Hi Power - Low RPM.*
- » *Komatsu Dual Mode - Torque converter & Direct Drive Modes.*

GD555-5	GD655-5
<b>HORSEPOWER</b>	<b>HORSEPOWER</b>
<b>Gross: 146kW</b>	<b>Gross: 165kW</b>
196 HP @ 2000 rpm	221 HP @ 2100 rpm
<b>Net: 144kW</b>	<b>Net: 163kW</b>
193 HP @ 2000 rpm	218 HP @ 2100 rpm
<b>OPERATING WEIGHT</b>	<b>OPERATING WEIGHT</b>
<b>18120 kg 39947 lb</b>	<b>18520 kg 40744 lb</b>
<b>BLADE LENGTH</b>	<b>BLADE LENGTH</b>
<b>3.71 m 12 ft</b>	<b>4.32 m 14 ft</b>



**Easy Serviceability**

- » *Easy radiator cleaning with (Hydraulic Reversing Fan) See page 7.*
- » *Hydraulic Driven Air Compressor with Reservoir (air on demand) See page 7.*
- » *Easy Re-Fuelling from (Ground level) See page 7.*

*Photo may include optional equipment.*

# ECOLOGY FEATURES

## Komatsu Technology

Komatsu develops and produces all major components, such as engines, electronics and hydraulic components in house.

Since all components can be matched, efficiencies are increased achieving high levels of productivity and ecology. With this "Komatsu Technology", and through customer feedback, Komatsu is achieving great advancements in technology.

The result is a new generation of high performance and environment friendly machines.

## High Performance SAA6D107E-1 Komatsu Engine

Electronic heavy duty common rail fuel injection system provides optimum combustion of fuel. This system also provides fast throttle response to match the machine's powerful tractive effort and productivity.

**GD555-5 NET: 144kW 193HP**  
**GD655-5 NET: 163kW 218HP**

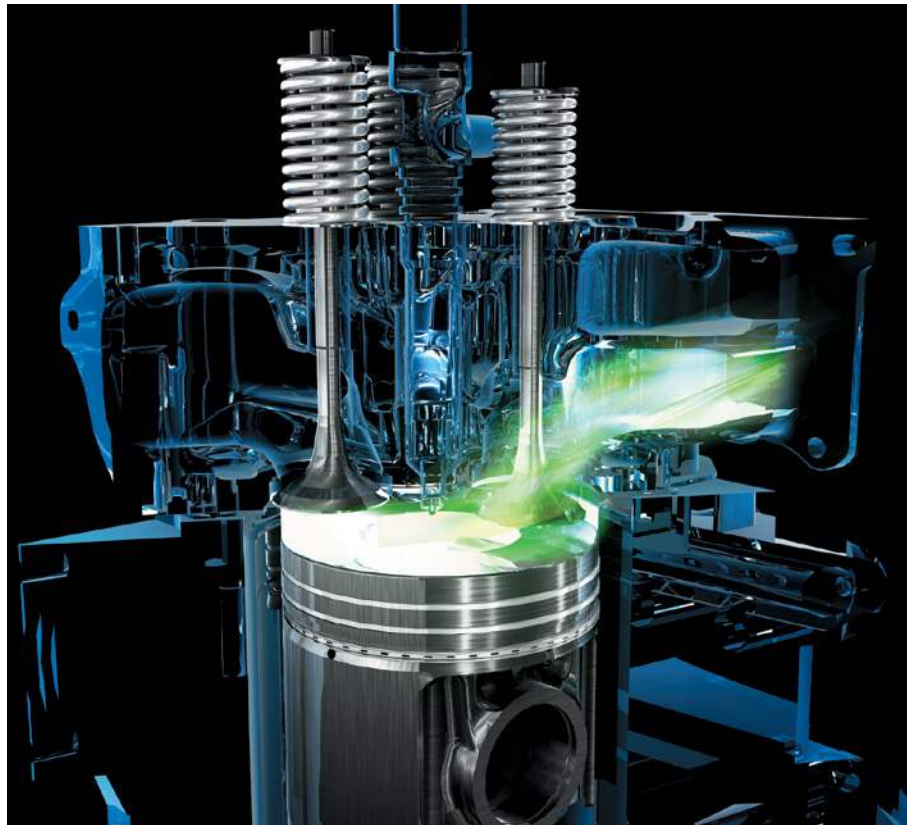

## Low Emission Engine

This engine is EPA Tier 3 emission regulation and EU Stage 3A emission regulation certified, without sacrificing power or machine productivity.

## Hydraulic Driven and Reversing Cooling Fan

Reduce power loss in case of low temperature and reduce engine noise.

## Outstanding Fuel Economy

A significant reduction in fuel consumption is achieved by the control of the engine speed.

## 2 Mode 3 Stage VHPC

The system allows selection of the appropriate mode between two modes <P mode> or <E mode> according to each working condition. The mode is easily selected with a switch in the operator's cab.

» **P Mode** Greater productivity can be attained by taking full advantage of high output power. It is appropriate for job sites where the motor grader meets high resistance.

» **E Mode** This mode is selected for maximum economy and lighter work applications. This feature provides the appropriate power and better fuel consumption.

## GD655-5

	kW (HP)			
	P		E	
	AUTO	MANUAL	AUTO	MANUAL
F1	134 (180)	134 (180)	108 (145)	108 (145)
F2				
F3				
F4	149 (200)	149 (200)	134 (180)	134 (180)
F5				
F6				
F7	163 (218)	163 (218)	149 (203)	149 (203)
F8				
R1	134 (180)	134 (180)	108 (145)	108 (145)
R2				
R3	149 (200)	149 (200)	134 (180)	134 (180)
R4				

## GD555-5

	kW (HP)			
	P		E	
	AUTO	MANUAL	AUTO	MANUAL
F1	118 (158)	118 (158)	104 (140)	104 (140)
F2				
F3				
F4	131 (176)	131 (176)	118 (158)	118 (158)
F5				
F6				
F7	144 (193)	144 (193)	131 (176)	131 (176)
F8				
R1	118 (158)	118 (158)	104 (140)	104 (140)
R2				
R3	131 (176)	131 (176)	118 (158)	118 (158)
R4				



# Converter Drive: Designed to Provide Power and Performance

## Komatsu Power Shift Transmission

Is designed and built specifically for Komatsu graders. The transmission provides on-the-go, full power shifting as well as inching capability and automatic shifting in the higher ranges.

### Lock-up Torque Converter (Auto Mode)

Or direct drive (manual mode), the operator chooses the optimum transmission set-up for the job at hand. If power for tough grading or low speed fine control is required, the operator can select the auto mode. With the torque converter, the operator has tremendous tractive effort and control.

More importantly, you can achieve fine control at low speed without shifting or using an inching pedal. Auto mode is available in gears 1-8. If high transport speed or high speed for snow removal is needed, the operator can select manual drive. The operator has the best of both worlds.

## Gear Selections

Eight forward speeds and four reverse speeds give the operator a wide operating range. With four gears when in auto mode, shifting is automatic in speeds five through eight. The operator sets the maximum gear for operation and the transmission then shifts automatically between gears four through eight up to the operator selected maximum gear.

## Electronic Overspeed Protection

Helps prevent engine and transmission damage from premature downshifting and grade-induced overspeeding.

## Electronic Transmission Control

Produces smooth shifting, which enables the operator to maintain a uniform grading surface if shifting is required. Smooth shifts also extend the life of the transmission clutches. A single lever controls direction, speed and parking brake.

## Low Effort Inching Pedal

Gives the operator precise control of machine movement.



		Position of gear shift lever												
		F-1	F-2	F-3	F-4	F-5	F-6	F-7	F-8	R-1	R-2	R-3	R-4	
AUTO MODE	Gear speed	F-1	○							R-1	○			
		F-2		○						R-2		○	○	
		F-3			○					R-3			○	○
		F-4				○	○	○	○	R-4				○
		F-5					○	○	○					○
		F-6						○	○					○
		F-7							○					○
		F-8												○
MANUAL MODE			●	●	●	●	●	●	●					

- : In lockup state (torque converter is not in use)
- : In torque converter state
- ⊙ : As the machine speed increases, torque converter state changes to lockup state.
- | : Automatic gear shift

## Superior Transmission with a New Function

Combination of a manual mode and auto mode is very effective for avoiding engine stalling which leads to low speed smooth operation.

No engine stalling when in manual mode due to the 'Non Stall Function'.

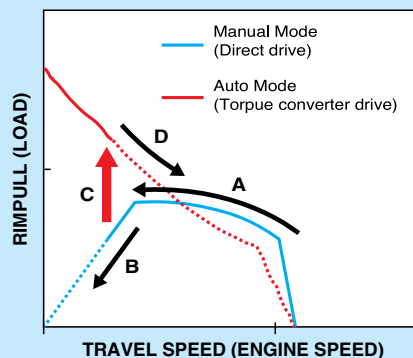

- A** If the load increases, the engine speed will down
- B** If the load increases further, the engine may stall
- C** Just before the engine stall, it automatically changes to auto mode (with torque converter) to avoid stalling
- D** When the load decreases and travel speed has recovered, it automatically returns to manual mode

# ADVANCED CONTROL FEATURES

## Power on Demand

Normally, the variable displacement pump idles at low output. When it senses a load requirement, the pump slides quick flow and pressure to match the demand. The result is less hydraulic system heat, quick response and lower fuel consumption. The bottom line is greater efficiency.

## Implement Control Valves

Designed and built by Komatsu specifically for motor graders. The valves are direct acting and provide outstanding operator "feel" and predictable system response to precise implement control. To help maintain exact blade settings, lock valves are built into the hydraulic circuits. Relief valves are also incorporated into selected circuits to protect the cylinders from over-pressurisation.

## Low Operating Effort

Implement controls are designed to reduce operator fatigue. They feature short lever throws and effort in both directions. Properly spaced control levers and short lever throws allow the operator to use multiple controls with one hand.

## Balanced Flow

When the operator uses several controls at the same time, flow is proportional to ensure several implements can operate simultaneously.

## Constant Implement Speed

Implement speed is constant regardless of engine speed because of the large pump output and proportional flow control function.



## Blade Angle

A long wheel base allows the operator to obtain an aggressive moldboard angle. This large blade angle permits material to roll more freely along the blade, which reduces power requirements. This is particularly helpful in dry soil or clay or for snow and ice removal.

## Rugged Construction

A one-piece forged circle is built to stand up to high stress loads. To reduce wear, teeth are induction hardened in the front 180 deg. of the circle. For maximum support, the circle is secured to the drawbar by six support shoes.

## Blade Protection System

### Standard Fitment

**Blade Lift Accumulators** absorb shocks when the moldboard contacts immovable objects. This is especially useful in rough grading and rocky areas. It allows precise control while allowing relief from vertical impact loads. This option is most useful in applications where hidden objects are frequently encountered.

## Versatile Moldboard Geometry

Komatsu graders feature a versatile moldboard geometry. Save time and money when pulling ditches by throwing the window to the right, not into the roadway, without narrowing the road bed. It's made possible by Komatsu's extraordinary reach and aggressive blade angle. Ample clearance between the heel of the blade and main frame, even with the toe sharply angled down.

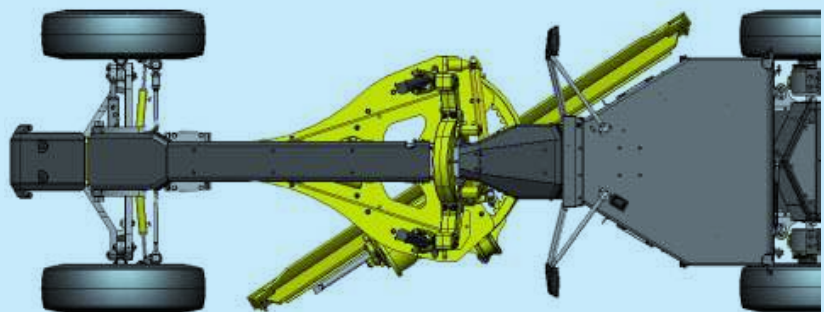

# Superior Serviceability

## Easy Access to Service Areas

- » Large hinged lockable doors are standard and provide easy access to the engine and radiator service points. Spin-on filters can be changed quickly.
- » The fuse panel is located in the cab. Circuits and fuse sizes are clearly identified.
- » The tandem oil check point is conveniently located at the end of the tandem.
- » The service meter is located in the electronic monitoring system.
- » Refuelling from the ground is easy.
- » Engine oil, hydraulic oil and coolant drains are eco friendly positioned with excellent accessibility.

## Easy Radiator Cleaning with Reversing Fan

Dust stuck to the radiator and cooler fins is blown off with reversal of the hydraulic drive fan.

## Power Train Components

With a modular design, you can remove the engine, transmission or final drives independently for quick service.

## Character Display is Easy to See

During normal operation, the service meter/odometer is displayed in this area. If abnormality or machine overload occurs, or if machine maintenance and inspection are required, action codes appear on the display to allow the operator to take appropriate action.

## Adjustment-free Oil Disc Brakes

Komatsu designs and builds multiple-disc brakes that are completely sealed and adjustment-free. The brakes are immersed in oil, and are hydraulically actuated. A fully hydraulic brake system eliminates problems associated with air systems. The large braking surface provides dependable braking capability and increased life before a rebuild is required.

## Environment Friendly

The engine and transmission are rubber-mounted to transmit less engine noise and vibration to the operator and extend component life. A lead-free aluminium core is used for the radiator to comply with global environmental requirements.

Easy radiator cleaning with reverse fan



Tandem tool box - standard equipment



Spin - on transmission filter



Lockable- ground level refuelling.



Console with central warning lamp. Internal monitoring system with error codes appearing in the display screen.



Auto Return to Center

# WORKING ENVIRONMENT

## Optional Topcon System 5 - 2D Cross Slope



Can Be Economically Expanded to 3D Hire Ready -3D Full System



Topcon System Five Monitor

Topcon Mainfall Sensor



Topcon Smart Knobs



Topcon Rotation Sensor



Topcon Cross Slope Sensor

### Articulation Automatic Return to Center



**"Increased Operator Performance & Ease of Operation"**

- » Articulation Auto Return to Center

### Excessive Idle Shut Down



**"Save Money"**

- » Excessive Idle Shutdown
- » Programmable
- » Decrease Wasteful Idle Time
- » Reduce Fuel Consumption
- » Increased Uptime
- » Increased Time between Services

# SPECIFICATIONS

## GD555-5



### ENGINE

Model	KOMATSU SAA6D107E-1	
Type	Water-cooled, 4 cycle, direct injection	
Aspiration	Turbocharged and air to air aftercooled	
Number of cylinders	6	
Bore	107 mm	
Stroke	124 mm	
Piston displacement	6.69 ltr	
Gross horsepower (Manual mode)		
P-mode		
Gear 1-3	120 kW	161 HP@2000 rpm
Gear 4-6	134 kW	179 HP@2000 rpm
Gear 7-8	146 kW	196 HP@2000 rpm
E-mode		
Gear 1-3	107 kW	143 HP@2000 rpm
Gear 4-6	120 kW	161 HP@2000 rpm
Gear 7-8	134 kW	179 HP@2000 rpm
Net flywheel horsepower* (Manual mode)		
P-mode		
Gear 1-3	118 kW	158 HP@2000 rpm
Gear 4-6	131 kW	176 HP@2000 rpm
Gear 7-8	144 kW	193 HP@2000 rpm
E-mode		
Gear 1-3	104 kW	140 HP@2000 rpm
Gear 4-6	118 kW	158 HP@2000 rpm
Gear 7-8	131 kW	176 HP@2000 rpm
Max. torque	880 Nm	89.8 kg.m 649 lb.ft@1450 rpm
Torque rise	29%	
Fan speed	Max. 1500 rpm	
Air cleaner	2-stage, dry-type	
Electrical	24 volt with 90 amp alternator	
Battery	2, low maintenance plus, 12 volt, 1146 cca	

\* Net flywheel HP output for standard (SAE J1349) including air cleaner, alternator (not charging), water pump, lubricating oil, fuel pump, muffler and fan running at minimum speed.



### TRANSMISSION & TORQUE CONVERTER

Full power shift transmission with integral free wheeling stator torque converter and lock-up.

Speeds (at rated engine speed)

Gear	Forward	Reverse
1st	3.4 km/h 2.1 mph	4.5 km/h 2.8 mph
2nd	5.0 km/h 3.1 mph	9.2 km/h 5.7 mph
3rd	7.0 km/h 4.3 mph	20.3 km/h 12.6 mph
4th	10.2 km/h 6.3 mph	40.3 km/h 25.0 mph
5th	15.4 km/h 9.6 mph	
6th	22.3 km/h 13.9 mph	
7th	30.6 km/h 19.0 mph	
8th	44.3 km/h 27.5 mph	



### TANDEM DRIVE

Oscillating welded box section	520 mm x 202 mm
Side wall thickness: Inner	22 mm
Outer	19 mm
Wheel axle spacing	1525 mm
Tandem oscillation	11° forward, 13° reverse



### FRONT AXLE

Type	Solid bar construction welded steel sections
Ground clearance at pivot	620 mm
Wheel lean angle, right or left	20°
Oscillation, total	32°



### REAR AXLE

Alloy steel, heat treated, full floating axle with lock/unlock differential.



### WHEELS, FRONT & REAR

Bearings	Tapered roller
Tyres	14.00 - 24 radial
Tyre rims (demountable)	10" three piece rims



### STEERING

Hydraulic power steering providing stopped engine steering complies with SAE J53.

Minimum turning radius	7.3 m
Maximum steering range, right or left	49°
Articulation	25°



### BRAKES

Service brake ..... Foot operated, oil disc brakes, hydraulically actuated on four tandem wheels, 13691 cm<sup>2</sup> 2122 in<sup>2</sup> total braking surface  
 Parking brake ..... Manually actuated, spring applied, hydraulically released caliper with transmission interlock



### FRAME

Front Frame Structure - Height	300 mm
Front Frame Structure - Width	300 mm
Front Frame Structure - Thickness	14 mm

# SPECIFICATIONS

## GD655-5



### ENGINE

Model .....	KOMATSU SAA6D107E-1	
Type .....	Water-cooled, 4 cycle, direct injection	
Aspiration .....	Turbocharged and air to air aftercooled	
Number of cylinders .....	6	
Bore .....	107 mm 4.21"	
Stroke .....	124 mm 4.88"	
Piston displacement .....	6.69 ltr 408 in <sup>3</sup>	
Gross horsepower (Manual mode)		
P-mode		
Gear 1-3 .....	136 kW	183 HP@2000 rpm
Gear 4-6 .....	151 kW	203 HP@2000 rpm
Gear 7-8 .....	165 kW	221 HP@2100 rpm
E-mode		
Gear 1-3 .....	110 kW	143 HP@2000 rpm
Gear 4-6 .....	136 kW	183 HP@2000 rpm
Gear 7-8 .....	151 kW	203 HP@2000 rpm
Net flywheel horsepower* (Manual mode)		
P-mode		
Gear 1-3 .....	134 kW	180 HP@2000 rpm
Gear 4-6 .....	149 kW	200 HP@2000 rpm
Gear 7-8 .....	163 kW	218 HP@2100 rpm
E-mode		
Gear 1-3 .....	108 kW	145 HP@2000 rpm
Gear 4-6 .....	134 kW	180 HP@2000 rpm
Gear 7-8 .....	149 kW	203 HP@2000 rpm
Max. torque .....	941 Nm	96.0 kg.m 694 lb.ft@1450 rpm
Torque rise .....	31%	
Fan speed .....	Max. 1500 rpm	
Air cleaner .....	2-stage, dry-type	
Electrical .....	24 volt with 90 amp alternator	
Battery .....	2, low maintenance plus, 12 volt, 1146 cca	

\* Net flywheel HP output for standard (SAE J1349) including air cleaner, alternator (not charging), water pump, lubricating oil, fuel pump, muffler and fan running at minimum speed.



### TRANSMISSION & TORQUE CONVERTER

Full power shift transmission with integral free wheeling stator torque converter and lock-up.

Speeds (at rated engine speed)

Gear	Forward	Reverse
1st	3.4 km/h 2.1 mph	4.5 km/h 2.8 mph
2nd	5.0 km/h 3.1 mph	9.2 km/h 5.7 mph
3rd	7.0 km/h 4.3 mph	20.3 km/h 12.6 mph
4th	10.2 km/h 6.3 mph	40.3 km/h 25.0 mph
5th	15.4 km/h 9.6 mph	
6th	22.3 km/h 13.9 mph	
7th	30.6 km/h 19.0 mph	
8th	44.3 km/h 27.5 mph	



### TANDEM DRIVE

Oscillating welded box section .....	520 mm x 202 mm
Side wall thickness: Inner .....	22 mm
Outer .....	19 mm
Wheel axle spacing .....	1525 mm
Tandem oscillation .....	11° forward, 13° reverse



### FRONT AXLE

Type Solid bar construction welded steel sections	
Ground clearance at pivot .....	620 mm
Wheel lean angle, right or left .....	20°
Oscillation, total .....	32°



### REAR AXLE

Alloy steel, heat treated, full floating axle with lock/unlock differential.



### WHEELS, FRONT & REAR

Bearings .....	Tapered roller
Tyres .....	17.5 - 25 radial
Tyre rims (demountable) .....	14" three piece rims



### STEERING

Hydraulic power steering providing stopped engine steering complies with SAE J53.

Minimum turning radius .....	7.4 m
Maximum steering range, right or left .....	49°
Articulation .....	25°



### BRAKES

Service brake ..... Foot operated, oil disc brakes, hydraulically actuated on four tandem wheels, 13691 cm<sup>2</sup> 2122 in<sup>2</sup> total braking surface  
 Parking brake ..... Manually actuated, spring applied, hydraulically released caliper with transmission interlock



### FRAME

Front Frame Structure - Height .....	300 mm
Front Frame Structure - Width .....	300 mm
Front Frame Structure - Thickness .....	14 mm



**DRAWBAR**

A-shaped, u-section press formed and welded construction for maximum strength with a replaceable drawbar ball.

Drawbar frame ..... **210 x 25 mm**



**CIRCLE**

Single piece rolled ring forging. Six circle support shoes with replaceable wear surface. Circle teeth hardened on front 180° of circle.

Diameter (outside) ..... **1530 mm**  
Circle reversing control hydraulic rotation 360 °



**MOLDBOARD**

Hydraulic power shift fabricated from high carbon steel. Includes replaceable metal inserts, cutting edge and end bits. Cutting edge and end bits are hardened.

GD555-5 Dimensions ..... **3710 x 645 x 22 mm** 12'2" x 2'1" x 0.75"  
GD655-5 Dimensions ..... **4320 x 645 x 25 mm** 14'2" x 2'1" x 0.98"  
Arc radius ..... **329 mm**  
Cutting Edge ..... **152 x 16 mm** 6" x 0.63"



**BLADE RANGE**

Circle center shift:  
Right ..... **590 mm**  
Left ..... **550 mm**  
Moldboard side shift:  
Right ..... **820 mm**  
Left ..... **820 mm**  
Maximum shoulder reach outside rear tyres (frame straight):  
Right ..... **2000 mm**  
Left ..... **2000 mm**  
Maximum lift above ground ..... **480 mm**  
Maximum cutting depth ..... **615 mm**  
Maximum blade angle, right or left ..... **90 °**  
Blade tip angle ..... **40 ° forward, 5 ° backward**



**HYDRAULICS**

Load-sending closed center hydraulics with variable displacement piston pump. Short stroke/low effort direct acting control valves with preselected maximum flow setting to each function. Double acting anti-drift check valves on blade lift, tip, circle shift, articulation and leaning wheels.

Output ..... **200 ltr/min** 52.8 U.S.gal/min@ 2000 rpm  
Standby pressure ..... **3.4 MPa** 35 kg/cm<sup>2</sup> 500 psi  
Maximum system pressure ..... **20.6 MPa** 210 kg/cm<sup>2</sup> 3,000 psi



**INSTRUMENT**

Electronic monitoring system with diagnostics:

Gauges:

Articulation, engine coolant temperature, fuel level, speed meter, T/M shift indicator, engine tachometer, torque converter oil temperature.

Warning lights/indicator:

Battery charge, brake oil pressure, blade float, brake oil pressure, inching temperature, directional indicator, engine oil pressure, hydraulic oil temperature, heater signal, lift arm lock, parking brake, differential lock, torque converter oil temperature, eco, P mode, fan reverse, rpm set, high beam, working lights



**CAPACITIES (refilling)**

Fuel tank ..... **416 ltr**  
Cooling system ..... **24.9 ltr**  
Crank case ..... **23.1 ltr**  
Transmission ..... **45 ltr**  
Final Drive ..... **17 ltr**  
Tandem Housing (each) ..... **57 ltr**  
Hydraulic system ..... **69 ltr**  
Circle reverse housing ..... **7 ltr**



**OPERATING WEIGHT (approx)**

**GD555-5** Includes lubricants, coolant, full fuel tank  
(Including Standard Equipment) Total ..... **18,120 kg**  
On rear wheels ..... **12,680 kg**  
On front wheels ..... **5,440 kg**  
GD555-5 Blade Down pressure ..... **8,768 kg**  
GD555-5 Blade pull ..... **11,412 kg**  
14.00 x 24 Tyres & Rims / 3.71m Blade

**GD655-5** Includes lubricants, coolant, full fuel tank  
(Including Standard Equipment) Total ..... **18,520 kg**  
On rear wheels ..... **13,150 kg**  
On front wheels ..... **5,371 kg**  
GD655-5 Blade Down pressure ..... **8,920 kg**  
GD655-5 Blade pull ..... **11,835 kg**  
17.5 x 25 Tyres & Rims / 4.32m Blade



**RIPPER**

Ripper Penetration Force – fitted with standard equipment

GD655 ..... **9,202 kgf** (90.0 kN)  
GD555 ..... **8,785 kgf** (85.8kN)

Ripper Pry Out Force – fitted with standard equipment

GD655 ..... **13,020 kgf** (127.6 kN)  
GD555 ..... **13,020 kgf** (127.6 kN)

# SPECIFICATIONS



## DIMENSIONS

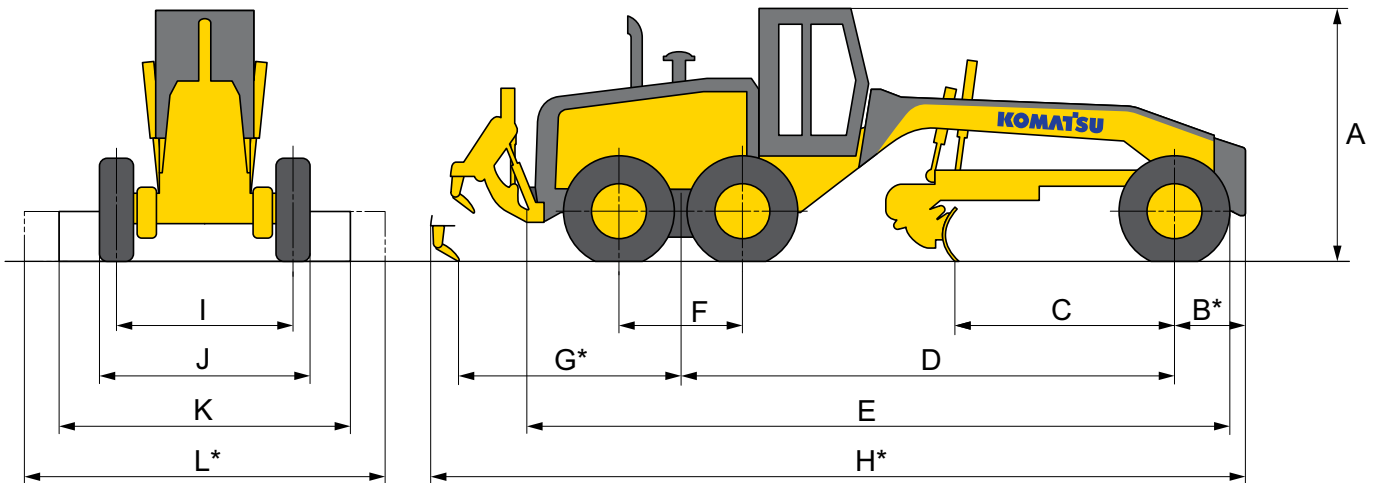
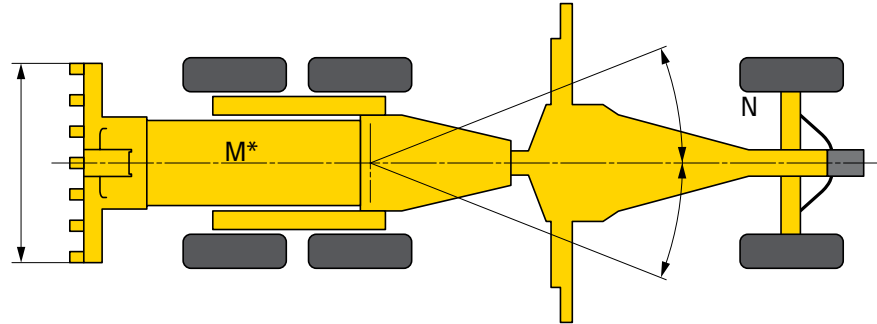

Dimensions		GD555-5	GD655-5
A	Height: Low profile cab:	3200 mm	3200 mm
B	Center of front axle to counterweight (Pusher)	927 m	927 mm
C	Center edge to center of front axle	2380 mm	2580 mm
D	Wheel base to center of tandem	6270 mm	6480 mm
E	Front tyre to rear bumper	8995 mm	9205 mm
F	Tandem wheelbase	1524 mm	1524 mm
G*	Center of tandem to back of ripper	2780 mm	2780 mm
H*	Overall length	10365 mm	10575 mm
I	Track gauge	2060 mm	2165 mm
J	Width of tyres	2490 mm	2600 mm
K	Width of moldboard (standard)	3710 mm	4320 mm
L*	Width of moldboard (optional)	4320 mm	3710 mm
M*	Ripper beam width	2305 mm	2305 mm
N	Articulation, left or right	25 °	
	Clearance	390 mm	390 mm



## STANDARD EQUIPMENT

### Engine And Related Item

- » Engine: *Komatsu SAA6D107E-1, EPA Tier-3 Certified*
- » *Turbocharged and Air Aftercooled, Standard VHP*
- » *GD555-5 144kW - Net kw*
- » *GD655-5 163kW - Net kw*
- » *Double Element Air Cleaner And Dust Indicator*
- » *Air Intake Extension*
- » *Pre-Cleaner, Turbo II*
- » *Fuel Line Pre-Filter*
- » *Hood-Sides For Engine Compartment*

### Electrical Systems

- » *Alternator, 90 Amp, 24 V*
- » *Reverse Alarm*
- » *Battery, Extreme Duty, 1146 Cca Each*
- » *Dome Light Cab*
- » *Horn, Electric*
- » *Lights: Back-Up, Stop, Tail, Directional, Front Bar Mounted*
- » *Work Lamps: Front (4), Rear (2)*
- » *Cab Mount Work Lamps (4)*
- » *Warning Light, LED Amber Beacons Guarded (2) Roof Mounted*
- » *Speedometer*
- » *Indicators: Parking Brake, Differential Lock, Blade Float, Lift Arm Lock, High Beam, Eco, Engine P Mode, Cooling Fan Reverse, Rpm Set, Engine Oil Pressure, Battery Charge, Brake Oil Pressure, Differential Oil Temperature*
- » *Rear Mounting Reversing Camera with Colour Monitor*

### Operator Environment

- » *Cab: Low Profile Enclosed with Insent ROPS/FOPS ISO 3471/ISO 3449*
- » *Safety Tinted Glass Windows*
- » *Tropical Roof Kit for High Ambient Extreme Conditions*
- » *Heavy Duty- High Ambient Air Conditioner (R134a)*
- » *Articulation Auto Return to Center*
- » *Console, Adjustable With Instrumental Panel Monitoring System*
- » *Mirrors: Interior Cab, Right And Left Exterior Mirrors*
- » *Seat, Air Suspension (150kg Capacity) Deluxe Adjustable Cloth with Retractable Seat Belt with Heavy Duty Komatsu Seat Cover*
- » *Sound Suppression, Cab And Floor Mat*
- » *Wipers, Front, Doors And Rear*
- » *12V (10A) Power Port Including 24V Power Port*
- » *Turbo Timer*

### Power Train

- » *Dual Mode Transmission (8F-4R) Power Shift, Direct Drive And Torque Converter With Auto Shift and Non-Stall Function*
- » *Axle, Rear Full Floating, Planetary Type*
- » *Service Brakes, Fully Hydraulic Wet Disc*
- » *Brake, Parking, Spring Applied, Hydraulic Release, Disc Type*
- » *Differential, Lock/Unlock*

### Work Equipment And Hydraulics

- » *Circle, Drawbar Mounted, 360° Rotation Hydraulic Blade Lift And Circle Side Shift*
- » *Circle Slip Clutch*
- » *Hydraulic System, Closed Center, Load Sensing*
- » *Accumulators, Anti-Shock For Blade Lift*
- » *Moldboard: 3710 mm x 645 mm x 22 mm*
- » *Moldboard: 4320 mm x 645 mm x 25 mm*  
*Hydraulic Blade Side Shift And Hydraulic Tilt With Anti-Drift Check Valves. Maximum Moldboard Angle Position 90° Right And Left.*
- » *Steering, Full Hydraulic With Tilt Steering Wheel Plus Leaning Front Wheels And Frame Articulation W/Anti-Drift Check Valves*
- » *10 Section Hydraulic Control Valve*
- » *Blade Lift Float Detent Style, Lh And Rh*
- » *Ripper, Assembly, Rear Mounted*
- » *Ripper Shanks And Points (3)*
- » *Scarifier, Shanks And Points (9)*

### Other Standard Equipment

- » *Certified Front Tie Down Plate*
- » *Painting, Komatsu Standard Colour Scheme*
- » *Steps And Handrails, Rear, Right And Left Side*
- » *Vandalism Protection Includes Lockable Access To Fuel Tank, Battery Cover, And Engine Side Covers*
- » *Tool Box With Lock On Tandem*
- » *Fuel Tank, Ground Level Access*
- » *Battery Disconnect Switch*
- » *Push Plate*
- » *Komtrax Step 2.5 Total Fleet Management Tool*
- » *Multi Media Radio Flush mounted into console with Blue Tooth, SD, & USB, SD & USB for charging Phone*
- » *Hydraulic Driven Air Compressor With Tank*
- » *Tyres: 14.00 x 24 Radial On 3 Piece 10" Rim*
- » *Tyres: 17.5 x R25 Radial On 3 Piece 13" Rim*
- » *Front Steering, Cylinder Guards*
- » *Large Tool Box In 'Y' Frame*

# SPECIFICATIONS



## OPTIONAL EQUIPMENT

### Blades

- » Moldboard: 4320 mm x 645 mm x 25 mm 14'2" x 2'1" x 0.98
- » Moldboard: 3710 mm x 645 mm x 22 mm 14'2" x 2'1" x 0.86
- » Moldboard Overlays
- » Spare Cutting Edge Carrier
- » Front Blade Lift or Lift & Tilt

### Tyres & Rims

- » Tyres: 17.5-25 Radial on 3 Piece 14" Rims (Width 2,600 Mm; Add 100 Kg for 6 Tyres and Rims)
- » Tyres: 14.00-24 Radial on 3 Piece 10" Rims (Width 2,490 Mm; Deduct 100 Kg for 6 Tyres and Rims)

### Spare Tyres & Rims

- » Spare Tyre Carrier Side Mount Rear – Hydraulic Raise Lower

### Machine Control Options

**Topcon 2D Cross Slope Easily converted to 3D Hire Ready.  
GD555-5 & GD655-5 can be fitted with Trimble or Leica Systems.**

**Request quotation from your Sales Account Manager.**

### Cabin

- » Hinged Rear-view Side Mirrors
- » Rear Window Internal Roll Up Blind
- » Cabin Pressuriser for Severe Applications»
- » Cabin External Air Conditioning Filtration for Severe Applications»
- » Engel Fridge 14 Litre with mounting frame

### Others

- » Tow Hitch Various Options
- » Grass Seed Kit for Severe Applications
- » Auto Lube Systems various Options
- » Lighting Package Protection
- » Over Dimension Signage
- » Hand Wash Dispenser

# KOMTRAX

## Why you need Komtrax

In today's fast changing environment information is key and the status and location of your equipment is paramount to successfully delivering on-time and on-budget. Komtrax gathers the information you need to manage your business easily and cost effectively.

Using the new Komtrax system you can track your equipment in the field and maximise output through increased efficiencies and just-in-time maintenance.

Komatsu has introduced Komtrax – the technologically advanced satellite equipment monitoring system to provide you with the following key features:

### FLEET MANAGEMENT

*Improve your fleet utilisation*

### MACHINE LOCATION

*Know exactly where your machine is*

### WORK MONITORING

*Know what your machine is doing*

### SECURITY

*Know if your machine is safe*

## How does Komtrax work?

Komtrax is a system which allows you to view all the information about your Komatsu equipment directly on your computer.

This information is downloaded via satellite and you can view what the operator sees on his monitor panel and the type of work the machine is doing.

The Komtrax information format is universal and allows you to see your complete Komtrax equipped fleet on one system.

*Komtrax can be easily accessed through a generic web browser.*

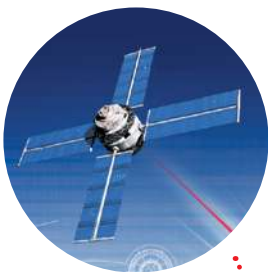

**1.** GPS satellite provides position information to your equipment in the field.



**2.** The Komtrax unit in your machine gathers engine data and position, and sends this information to the satellite.

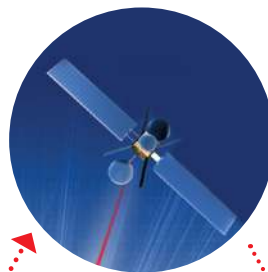

**3.** The communication satellite transmits information to the Komtrax data centre.



**4.** The Komtrax data centre stores and distributes the information throughout the machine life.



**5.** You can access the information gathered from your machine directly via the Internet from the Komtrax data centre.

**Australia** - Ph: 1300 566 287 | Web: [www.komatsu.com.au](http://www.komatsu.com.au)  
**New Zealand** - Ph: 0800 566 2878 | Web: [www.komatsu.co.nz](http://www.komatsu.co.nz)  
**New Caledonia** - Ph: +687 43 53 06  
**Email** - [info@komatsu.com.au](mailto:info@komatsu.com.au)

**KOMATSU**



Form Number: ZESS003000\_SEP2020