

HYDRAULIC EXCAVATOR

**TAKEUCHI**<sup>TM</sup>  
From World First to World Leader

# TB2150



Operating Weight: 15,095 kg

# Product Features & Specifications

## ENGINE

- EU Stage IV / EPA Tier 4 Emission Compliant
- DOC+SCR Exhaust After Treatment
- Automatic Fuel Bleed System
- Double Element, Air Cleaner
- Auto Deceleration
- Working Modes: Standard, ECO and High Altitude
- Fuel Supply Pump
- High Capacity Fuel Filters
- Hydraulic Fan Drive for Radiator
- V-rib Belt with Automatic Tensioner
- Engine Safety Start System on the Left Console
- Engine Auto Stop

## ELECTRICAL

- 7" Multi-Informational Display
- Rear View Camera
- Sealed Rocker Switches
- Beacon Socket and Lamp Switch
- Hour Meter
- Travel Alarm
- LED Light Standard Package
  - Front Cab x2
  - Front Cover x1
  - Boom x1
- Horn
- Additional LED Boom Light (optional)
- LED Cab Rear Light (optional)
- TFM (Takeuchi Fleet Management; GPS\*)
- TSS (Takeuchi Security System; Immobilizer) (optional)\*

## OPERATOR'S STATION

- Cab with Air Conditioner, Windshield Wiper and Washer, Skylight with Sunshade, Rain Guard, AM / FM / MP3, Bluetooth Radio, 12V / 24V Power Outlet
- ROPS / OPG (TOP Guard, Level II)
- OPG Level II Roof Guard Kit
- Deluxe High Back Seat
- 2" Retractable Seat Belt
- Tool Box
- Air Suspension Seat with Heat (optional)
- OPG Level II Front Guard (optional)

## WORKING EQUIPMENT

- Independent Mono Boom Swing
- Cushioned Boom, Arm and Swing Cylinders
- Two Boom Cylinders
- 2,320 mm Arm
- 2,570 mm Arm
- Arm and Boom Holding Valve with Lift Alarm
- Pattern Change Valve (ISO or G) (optional)

## TAKEUCHI FLEET MANAGEMENT

- Minimize Downtime
- Remote Diagnostics
- Utilization Tracking
- Proactive Maintenance
- Control Costs

## HYDRAULIC

- Variable Displacement, Open Center Hydraulics
- Hydraulic Joystick Controls
- Proportional Control for Service Port 1
- High Flow for Service Port 1 (optional)
- Proportional Control for Service Port 2
- Service Port 3 for Quick Hitch
- Proportional Control for Service Port 4 (optional)
- Adjustable Auxiliary Flow for Service Port 1, 2, and 4
- Pressure Adjustment for Service Port 1, 2, and 4 (optional)
- Auto Pressure Release (optional)
- Hydraulic Selector Valve (1 - Way / 2 - Way)
- Pilot Accumulator
- Air Breather, Hydraulic Tank
- Auto Tank (optional)

## UNDERCARRIAGE AND FRAME

- Triple Flanged Track Rollers
- 2-Speed Travel with Automatic Shift
- High Torque Planetary Final Drive
- Dozer Blade with Float (optional)
- Wraparound Counterweight
- Heavy Counterweight (optional)
- 500W Rubber Crawlers
- Steel Crawlers (500W / 600W / 700W) (optional)
- 500W Segmental Rubber Crawlers (optional)
- Rubber Pads for 500W Steel Crawlers (optional)



LCD Display



Automotive Styled Interior

\*Functions may not be available in all countries, so please consult your Takeuchi dealer for details.

# TOUGH, POWERFUL, RELIABLE



Large Floor with Foot Rest



Wraparound Counterweight



Triple Flanged Track Rollers



LED Work Lights

The new TB2150 hydraulic excavator delivers greater functionality, performance, comfort, and serviceability.

A completely redesigned operator's station features a large, intuitive multi-information color monitor, deluxe high back air suspension seat with heat for greater comfort, multi-function switch bank, and automatic climate control to keep the operator comfortable throughout the year.

The pivot boom configuration is unique and it allows the TB2150 to function like our smaller excavators. A standard rubber crawlers enable the TB2150 to work on a wide range of surfaces.

Additional features include up to four auxiliary hydraulic circuits for greater attachment versatility, boom and arm holding valves for added protection, and a large wrap around counterweight for stability.



Large lockable service hood provide vandalism protection and outstanding maintenance access.

## OPERATING PERFORMANCE

Operating Weight	15,095 kg
Bucket Capacity (Heaped)	0.45 m <sup>3</sup>
Slew Speed	10.8 min <sup>-1</sup>
Travel Speed	
1st	3.1 km/h
2nd	5.5 km/h
Gradeability	35°
Ground Pressure	47.1 kPa
Maximum Bucket Breakout Force	96.3 kN
Maximum Arm Digging Force (2,320 mm Arm)	59.8 kN
Maximum Arm Digging Force (2,570 mm Arm)	55.8 kN
Traction Force	145 kN
Boom Swing Angle (Left/Right)	77°/ 53°

## ENGINE

Model	DEUTZ TCD3.6L4
Rated Output (ISO 14396)	85 kW/2000 min <sup>-1</sup>
Maximum Torque	460 Nm/1600 min <sup>-1</sup>
Displacement	3,621 ml
Alternator	28 V-2.24 kW
Battery (IEC 60095-1)	12 V - 90A·h x 2

## FLUID CAPACITIES

Engine Lubrication	10 L
Cooling System	27 L
Fuel Tank Capacity	278 L
Hydraulic Reservoir Capacity	107 L
Hydraulic System Capacity	234 L
DEF Tank Capacity	20 L

## SAFETY and HEALTH

Vibration Levels	
Hand / Arm	≤ 2.5 m/s <sup>2</sup>
Body	≤ 0.5 m/s <sup>2</sup>
Noise Level	
Sound Power Level	LWA 98 dB

## HYDRAULIC SYSTEM

P1, P2	Variable Displacement Pump
Flow Rate	112 L/min
Relief Pressure	34.3 MPa
P3	Gear Pump
Flow Rate	20 L/min
Relief Pressure	3.9 MPa
P4	Gear Pump
Flow Rate	54.8 L/min
Relief Pressure	23.6 MPa
Service Port 1	
Flow Rate	112 L/min
Flow Rate - High Flow	224 L/min
Hydraulic Pressure	24.5 MPa
Service Port 2	
Flow Rate	54.8 L/min
Hydraulic Pressure	23.6 MPa
Service Port 3	
Hydraulic Pressure	21.0 MPa
Service Port 4	
Flow Rate	54.8 L/min
Hydraulic Pressure	23.6 MPa

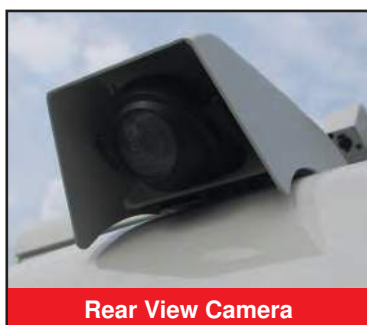

Rear View Camera



Multi-Function Switch Bank



Hydraulic Fan Drive for Radiator



Optional Dozer Blade with Float

# TB2150 Compact Excavator

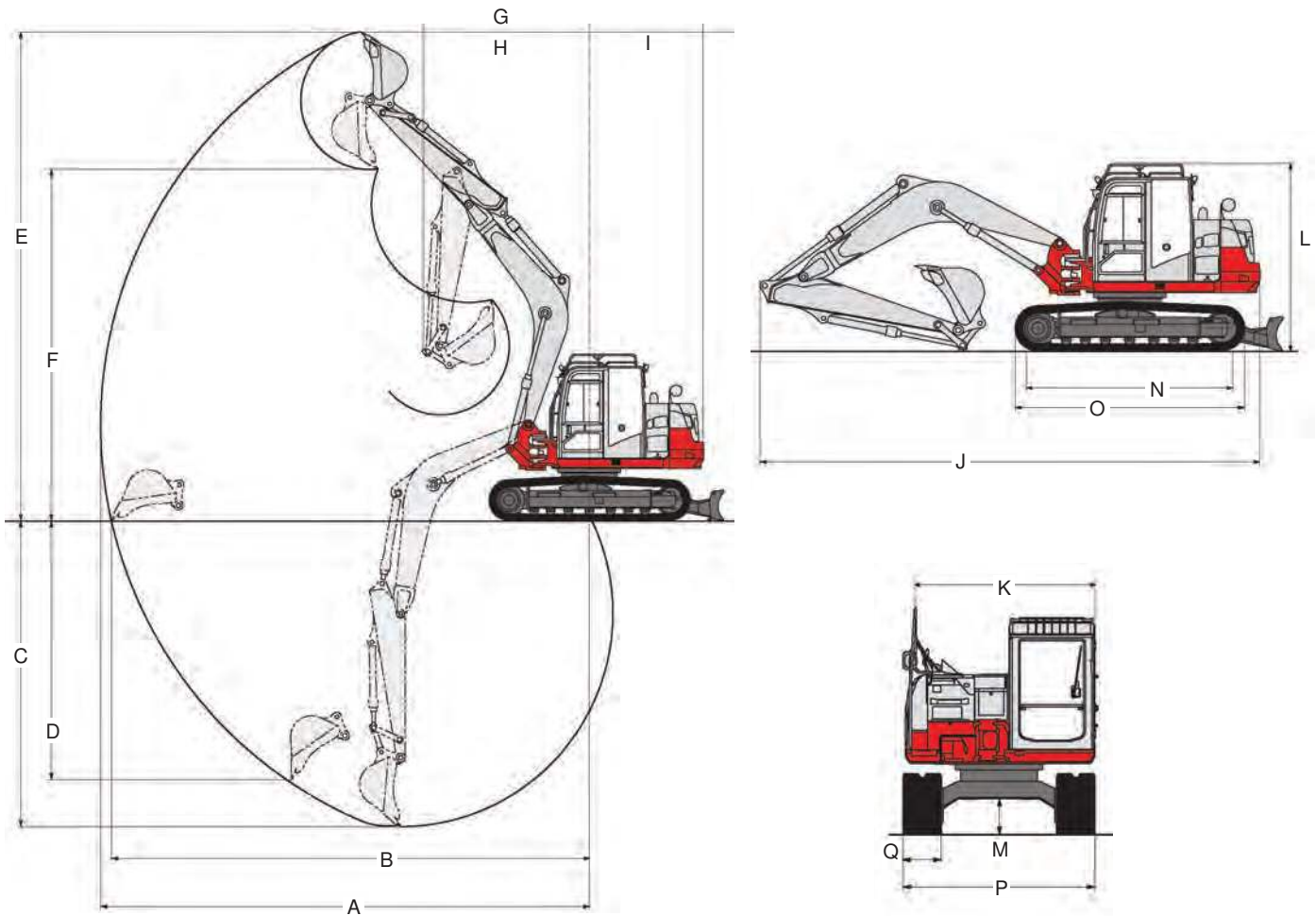

MACHINE DIMENSIONS	2,320 mm ARM	2,570 mm ARM
A Maximum Reach	8,520 mm	8,760 mm
B Maximum Reach at Ground Level	8,320 mm	8,565 mm
C Maximum Digging Depth	5,195 mm	5,445 mm
D Maximum Vertical Digging Depth	4,365 mm	4,605 mm
E Maximum Height of Cutting Edge	8,520 mm	8,700 mm
F Maximum Dumping Height	6,070 mm	6,250 mm
G Front Swing Radius	2,965 mm	3,015 mm
H Front Swing Radius with Boom Offset	2,360 mm	2,405 mm
I Slew Radius		2,000 mm
I' Slew Radius with Extra Weight		2,050 mm
J Overall Length	7,770 mm	7,805 mm
J' Overall Length with Extra Weight	7,820 mm	7,855 mm
K Upper Structure Overall Width		2,500 mm
L Overall Height		2,960 mm
M Ground Clearance		475 mm
N Crawler Base		2,895 mm
O Crawler Overall Length		3,615 mm
P Crawler Overall Width		2,490 mm
Q Crawler Shoe Width		500 mm

