

COMPACT TRACK LOADER

TL6R

takeuchiTM

From World First to World Leader

PROUDLY DISTRIBUTED BY



MATERIAL HANDLING

1800 425 438

toyotatakeuchi.com.au



Operating Weight: 3,395 kg

Product Features & Specifications

ENGINE

- EU Stage V / EPA Tier 4 Emission Compliant
- Turbocharged
- DOC+DPF Exhaust After Treatment
- Active Power Control Power Management System
- ECO Mode
- Foot Throttle Control
- Automatic Fuel Bleed System
- High Capacity Radiator and Hydraulic Oil Cooler Mounted Side-by-Side on Swing Out Frame
- Double Element, Air Cleaner

ELECTRICAL

- 5.7" Color Multi-Informational Display
- Rear Camera (optional)
- Sealed Rocker Switches
- 12 volt System with 60 amp Alternator
- LED Work Lights, Front and Rear
- Engine Preheat
- Hour Meter
- Back-up Alarm
- Horn
- TFM (Takeuchi Fleet Management; GPS)*

UNDERCARRIAGE AND FRAME

- Double Reduction Planetary Track Drives
- Permanently Sealed Track Rollers with Metal Face Seals
- Fully Welded Frame with Integrated Cross Members
- Front and Rear Tie-Down and Lift Points
- Integrated Rear Bumper
- Two-Speed Travel with Auto Shift Down
- 320 mm Quiet Ride Track Design

OPERATOR'S STATION

- Tilt-up Operator's Station
- Deluxe Adjustable Suspension Seat
- Rear Pivoting Seat Bar with Integrated Arm Rest
- ROPS / FOPS Level I
- Retractable 2" Seat Belt
- 3 Point Seat Belt (optional)
- Pressurized Cab with Swing Out Door, A/C, Heat, Defrost and Front Wiper, AM/FM/MP3 Radio (Cab Only)
- Rear Wiper (Cab Standard Equipment in Europe Only)

HYDRAULIC & WORKING EQUIPMENT

- High Lift Radial Arm Design
- Cushioned Arm Cylinders
- Boom Float with Detent
- Hydraulic Pilot Controls
- Proportional Auxiliary Controls with Detent
- Pressure Relieving 1/2" Flat Faced Coupler Body
- 14-Pin Connector with Push Button Control (optional)
- Hydraulic Self Leveling
- Mechanical Quick Hitch
- Hydraulic Quick Hitch (optional)

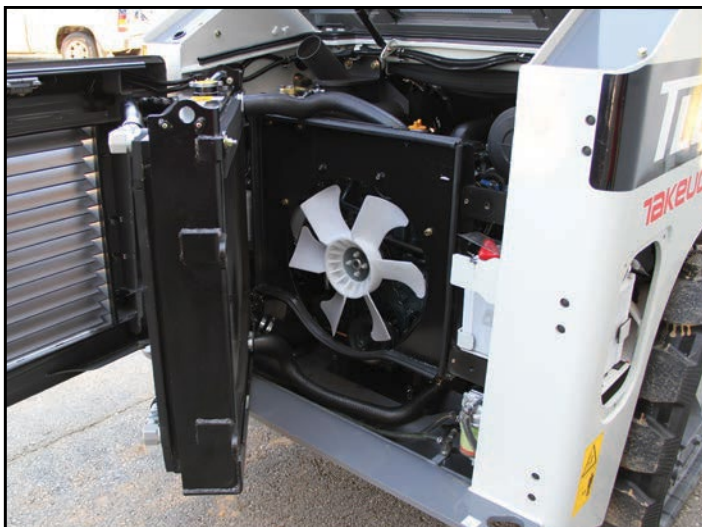

Convenient Service and Maintenance Access



Integrated Undercarriage

*Functions may not be available in all countries, so please consult your Takeuchi dealer for details.

TOUGH, POWERFUL, RELIABLE



Fully Welded Frame

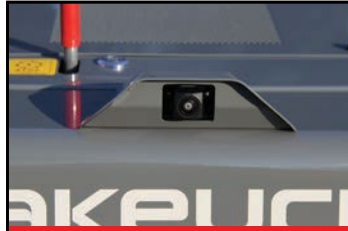

Optional Rear View Camera



Active Power Control



Cab with Swing Out Door

The TL6R provides an excellent blend of power and performance featuring a emission compliant engine. It has a bucket breakout force of 26.4 kN and traction force of over 38.5 kN giving it plenty of power to excavate, grade, and maneuver on the job site.

With a height of 1,975 mm and a width of 1,530 mm the dimensions of the TL6R allow it to excel on job sites with height and width restrictions.

The interior of the machine has rocker switches and color multi-informational display laid out intuitively overhead within easy reach of the operator.

Pilot controls deliver unmatched precision and control, and they are low effort to minimize operator fatigue. Active Power Control allows the operator to maintain optimum engine speed for maximum power when under load. An optional rear view camera and wide angle rear view mirror provide the operator with greater peace of mind during operation.

With a heavy duty swing out door and tilt up cab the TL6R provides outstanding serviceability. Access to oil fill, air cleaner, and water separator are accessible from the rear of the machine. Battery access is available through a bolt-on panel located on the right tower.

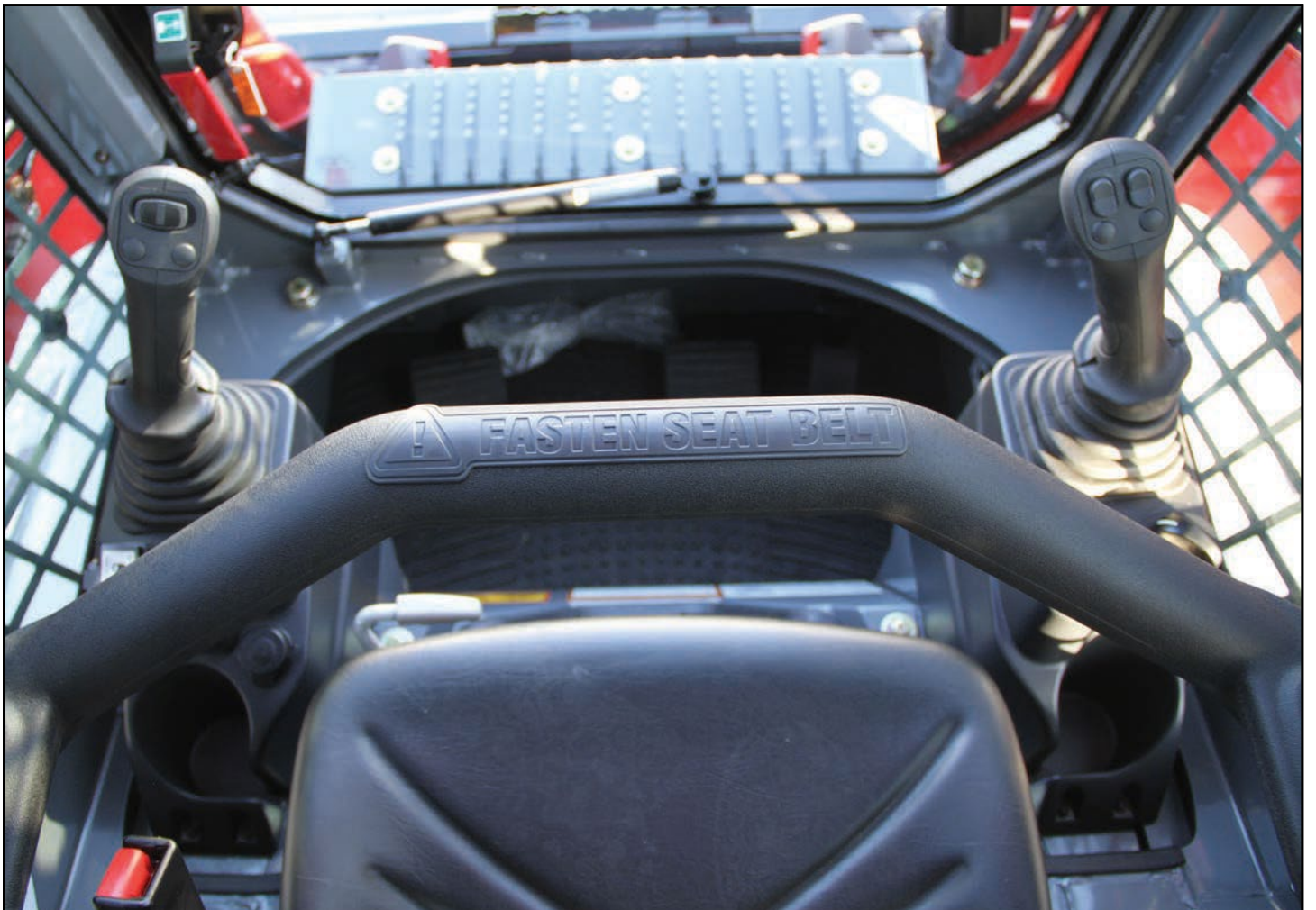

Spacious operator's platform with easy to reach controls and switches.

OPERATING PERFORMANCE

Operating Weight - Canopy	3,395 kg
Cab	3,530 kg
Tipping Load	2,390 kg
Rated Operating Capacity, (ISO 14397-1)*	835 kg
Operating Load at 50% of Tipping Load	1,195 kg
Bucket Breakout Force	26.4 kN
Lift Arm Breakout Force	21.6 kN
Traction Force	38.5 kN
Ground Pressure - Canopy	33.5 kPa
Ground Pressure - Cab	34.8 kPa
Travel speed - Low	7.0 km/h
High	10.0 km/h

*Operating capacity of track loaders is rated according to ISO 14397-1 at no more than 35% of the tipping load.

HYDRAULIC SYSTEM

Auxiliary Flow - Primary Circuit	67.0 L/min
Hydraulic System Pressure	20.6 MPa

ENGINE

Make / Model	Kubota / V2403
Engine Displacement	2,434 ml
Rated Output (ISO 14396)	47.9 kW / 2,700 min-1
Maximum Torque	195.6 Nm / 1,600 min-1

FLUID CAPACITIES

Engine Lubrication	7.6 L
Cooling System	13.0 L
Fuel Tank Capacity	75.7 L
Hydraulic Reservoir Capacity	30.0 L
Hydraulic System Capacity	51.0 L

SAFETY AND HEALTH

Vibration Levels	
Hand / Arm	$\leq 2.5 \text{ m/s}^2$
Body	$\leq 0.5 \text{ m/s}^2$
Noise Level	
Sound Power Level	LWA 103 dB



Multi-Informational Display



Hydraulic Joystick Controls



Switch Bank



Large Rear View Mirror

TL6R Compact Track Loader

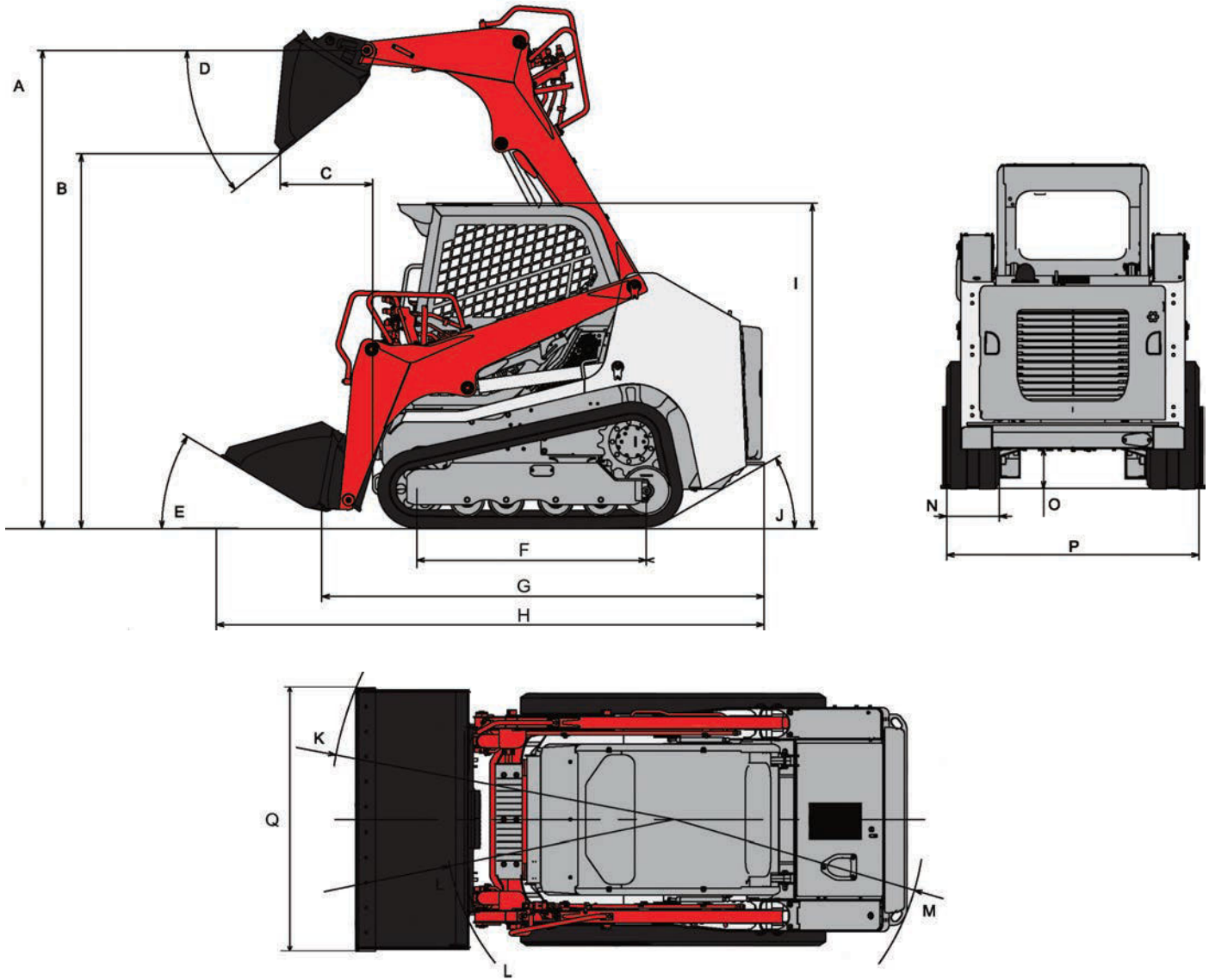

MACHINE DIMENSIONS

A	Maximum Lift Height to Bucket Pin	2,905 mm
B	Dump Height Fully Raised	2,275 mm
C	Dump Reach Fully Raised	560 mm
D	Dump Angle	40°
E	Rollback Angle	30°
F	Track Base	1,395 mm
G	Machine Length	2,690 mm
H	Transport Length	3,330 mm
I	Transport Height	1,975 mm
J	Departure Angle	30°
K	Clearance Circle with Bucket	2,095 mm
L	Clearance Circle without Bucket	1,395 mm
M	Clearance Circle Rear	1,520 mm
N	Track Width	320 mm
O	Ground Clearance	230 mm
P	Overall Width without Bucket	1,530 mm
Q	Bucket Width	1,600 mm



PROUDLY DISTRIBUTED BY
 **TOYOTA**
MATERIAL HANDLING
1800 425 438
toyotatakeuchi.com.au

© 2019 Takeuchi MFG. Co., Ltd. All Rights Reserved. In accordance with our established policy of continued improvement, specifications and features are subject to change without notice. Pictures may show options other than standard equipment.

FORM: TL6R Compact Track Loader Spec Sheet - Apr. 2019