

# TECHNICAL DATA

SINGLE DRUM ROLLERS

BW 124 DH-5, BW 124 PDH-5

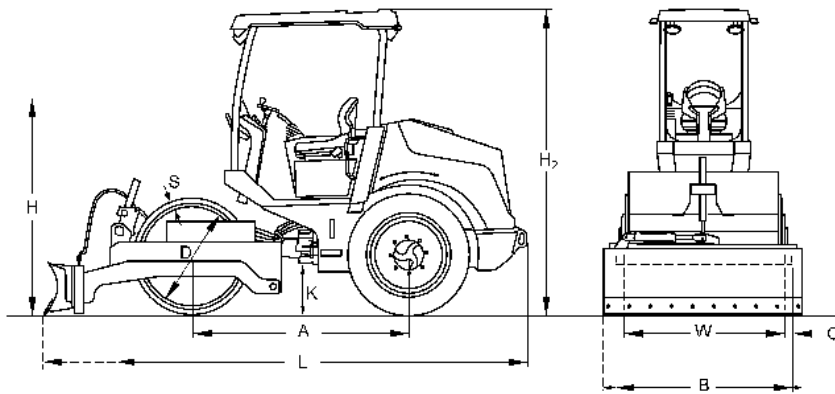



**Dimensions in mm**

	<b>A</b>	<b>B</b>	<b>D</b>	<b>H</b>	<b>H2</b>	<b>K</b>	<b>L</b>	<b>O</b>	<b>S</b>	<b>W</b>
<b>BW 124 DH-5</b>	1815	1310	960	1850	2520	320	3520	55	15	1200
<b>BW 124 PDH-5</b>	1815	1310	920	1850	2520	320	3520	55	15	1200

**Shipping dimensions in m3**

**BW 124 DH-5**  
**BW 124 PDH-5**

**without ROPS**

8,531  
8,531

**with ROPS**

11,620  
11,620

<b>Machine type</b>	<b>Compaction output (m3/h)</b>			
	<b>Rock fill</b>	<b>Gravel, sand</b>	<b>Mixed soil</b>	<b>Silt, clay</b>
BW 124 DH-5	-	105-210	75-150	40-90
BW 124 PDH-5	-	105-210	75-150	50-100

<b>Machine type</b>	<b>Compacted layer thickness (m)</b>			
	<b>Rock fill</b>	<b>Gravel, sand</b>	<b>Mixed soil</b>	<b>Silt, clay</b>
BW 124 DH-5	-	0,35	0,25	0,15
BW 124 PDH-5	-	0,35	0,25	0,20

**Technical Data****BOMAG  
BW 124 DH-5****BOMAG  
BW 124 PDH-5****Weights**

Grossweight .....	kg	3.950	4.000
Operating weight CECE .....	kg	3.300	3.390
Axle load, drum / wheels CECE .....	kg	1.520/1.730	1.600/1.790
Static linear load CECE .....	kg/cm	12,7	

**Dimensions**

Working width .....	mm	1.200	1.200
Track radius, inner .....	mm	2.260	2.260

**Driving Characteristics**

Speed .....	km/h	0- 9,0	0- 9,0
Max. gradeability without/with vibr. ....	%	55/55	55/55

**Drive**

Engine manufacturer .....		Kubota	Kubota
Type .....		V2403	V2403
Emission stage .....		Stage IV / TIER4f	Stage IV / TIER4f
Exhaust gas aftertreatment .....		DPF	DPF
Cooling .....		water	water
Number of cylinders .....		4	4
Performance ISO 3046 .....	kW	34,0	34,0
Performance SAE J 1995 .....	hp	46,0	46,0
Speed .....	min-1	2.400	2.400
Fuel .....		Diesel	Diesel
Electric equipment .....	V	12	12
Drive system .....		hydrost.	hydrost.
Drum driven .....		standard	standard

**Drums and Tyres**

Tyre size .....		9.5-24 4PR	9.5-24 4PR
-----------------	--	------------	------------

**Brakes**

Service brake .....		hydrost.	hydrost.
Parking brake .....		hydromec.	hydromec.

**Steering**

Steering system .....		oscil.artic.	oscil.artic.
Steering method .....		hydrost.	hydrost.
Steering / oscillating angle +/- .....	grad	35/12	35/12

**Exciter system**

Drive system .....		hydrost.	hydrost.
Frequency .....	Hz	41	41
Amplitude .....	mm	1,70	1,60
Centrifugal force .....	kN	85	85

**Capacities**

Fuel .....	l	60,0	60,0
------------	---	------	------

Technical modifications reserved. Machines may be shown with options.

### Standard Equipment

- Hydrostatic travel and vibration drive
- Double pump system for travel drive
- 2 Spring accumulator brakes
- Differential lock
- Hydrostatic articulated steering
- Contact scrapers
- Operating/Control Equipment
  - Hour meter
  - Charge control
  - Parking brake
  - Engine oil pressure
  - Engine temperature
  - air cleaner pollution
  - Fuel level indicator
- Warning horn
- Transport lashing and lifting points  
front/rear
- Lockable anti vandal dashboard protection
- Back-up alarm
- Emergency stop button
- ROPS/FOPS with safety belt
- Working lights
- Seat contact switch
- Battery disconnect switch

### Optional Equipment

- ECONOMIZER
- Dozer blade (+350kg/772lb)
  - B:1.515mm/59.6in
  - L:3.900mm/153.5in
- Dozer blade (Pre-installation)
- Dozer blade with tilting mechanism  
(+440kg/970lb)
- Working lights
- Rear windscreen
- Dozer blade
- Special painting
- Rotary beacon
- Comfort package
- TELEMATIC

