

DEVELON

Dozer

DD130



Engine

Make	PERKINS
Model	1204J
Number of cylinders	4
Rated power, gross (hp per SAE J1995)	156.9 hp (117.0 kW) @ 2200 rpm
Rated power, net (hp per SAE J1349)	146.1 hp (108.9 kW) @ 2200 rpm
Max. torque, net (SAE J1995)	523.7 lbf. ft. (710.0 Nm) @ 1400 rpm
Displacement	268.5 in. ³ (4.4 L)
Bore and stroke	4.1" x 5.0" (105 mm x 127 mm)
Starter	24 V, 10.5 hp (7.8 kW)
Battery	2 x 12 V, 100 AH
Alternator	24 V, 100 A
Air cleaner	Dual element

Hydraulics

Main variable displacement axial piston pump	34.9 gpm (132.0 L/min.)
Relief pressure (normal)	3843.5 psi (265.0 bar)

Undercarriage

Upper rollers (each track)	2
Lower rollers (each track)	8
Number of shoes (links per side)	41

Drive System

Type	Hydrostatic
Travel speed (low – high)	0 – 5.6 mph (0 – 9.0 km/h)
Max. traction force (drawbar pull)	49279.5 lbf. (22353.0 kgf)
Max. grade	70% (35°)

Environment

Sound level (2000/14/EC)	106 dB(A)
Cabin sound level (ISO 6396)	76 dB(A)

Refill Capacities

Fuel tank	58.6 gal. (222.0 L)
DEF tank	5.0 gal. (19.0 L)
Cooling system (radiator capacity)	11.8 gal. (44.6 L)
Engine oil	3.3 gal. (12.4 L)
Final drive (each side)	1.2 gal. (4.5 L)
Hydraulic tank	24.6 gal. (93.0 L)

All capacities are approximate values. Always refer to the machine's OM for exact refill levels. Check the dipstick, level eye, level plug, etc., to achieve the correct level.

Hydraulic Cylinders

Blade lift (2) bore x rod diameter x stroke	3.9" x 2.2" x 14.3" (100 mm x 55 mm x 362 mm)
Blade angle (2) bore x rod diameter x stroke	3.5" x 2.0" x 18.2" (90 mm x 50 mm x 461 mm)
Blade tilt (1) bore x rod diameter x stroke	4.3" x 2.6" x 5.5" (110 mm x 65 mm x 140 mm)
Ripper lift (1) bore x rod diameter x stroke	4.9" x 2.8" x 14.3" (125 mm x 70 mm x 362 mm)

The piston rods and cylinder bodies are made of high-strength steel. A shock-absorbing mechanism is fitted in all cylinders to ensure shock-free operation and extended piston life.

Dimensions

		XL Blade	LGP Blade
Blade type		XL	LGP
Overall shipping length (with drawbar)	A ₁	18' 11.1" (5769 mm)	
Overall shipping length (with ripper)	A ₂	19' 9.4" (6030 mm)	
Overall shipping height	B	10' 3.2" (3130 mm)	
Overall shipping width (blade straight)	C	10' 2.2" (3105 mm)	11' 11.9" (3655 mm)
Tumbler length	D	8' 11.1" (2720 mm)	
Overall track length	E	12' 1.3" (3690 mm)	
Undercarriage width	F	7' 7.7" (2330 mm)	9' 0.7" (2760 mm)
Track gauge width	G	5' 9.7" (1770 mm)	6' 6.7" (2000 mm)
Track grouser width	H	22.0" (560 mm)	29.9" (760 mm)
Ground clearance	I	14.0" (355 mm)	

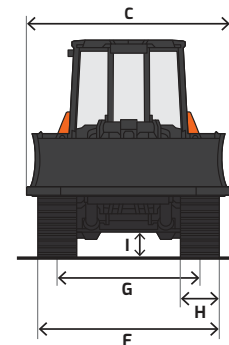
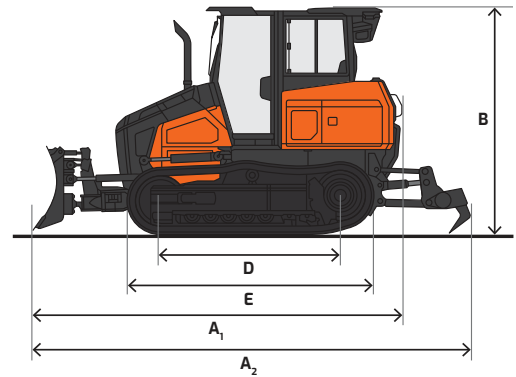

Working Range

		XL Blade	LGP Blade
Blade type		XL	LGP
Blade capacity (SAE)		4.6 yd ³ (3.5 m ³)	5.5 yd ³ (4.2 m ³)
Blade width	A ₁	10' 2.2" (3105 mm)	11' 11.9" (3655 mm)
Blade width at max. angle	A ₂	9' 5.0" (2870 mm)	11' 0.7" (3370 mm)
Blade height	B	3' 7.9" (1115 mm)	
Blade angle, max.	C	± 25°	
Blade tilt angle, max.	D	± 8°	
Blade pitch (adjustable)*		52° - 58°	
Blade digging depth	E	1' 3.9" (405 mm)	
Blade lift height	F	3' 7.7" (1110 mm)	
Ripper digging depth, max.*		11.0" (280 mm)	
Ripper overall width	G	6' 1.2" (1860 mm)	
Ripping width	H	5' 8.5" (1740 mm)	
Number of ripper shanks		3	
Distance between ripper shank	I	2' 10.3" (870 mm)	
Operating weight (with drawbar)		31074 lb. (14095 kg)	32037 lb. (14532 kg)
Ground pressure		6.0 psi (41.2 kPa)	4.6 psi (31.4 kPa)

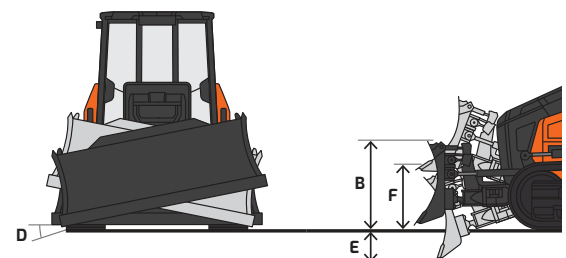
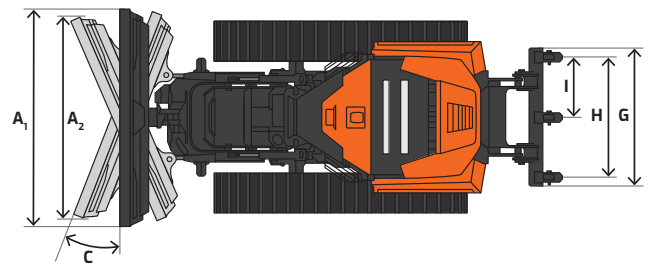

*Not shown on diagram

Standard & Optional Equipment

| Standard Base Package

■ Standard • Optional

Engine

Emissions (EPA), T4	■
Diesel oxidation catalyst (DOC)	■
Selective catalytic reduction (SCR)	■
Diesel particulate filter (DPF)	■
Direct fuel injected	■
Fuel filter with water separator	■
Coolant recovery tank	■
Dual element dry-type air filter	■
Electronic engine control	■
Auto idle	■
Overheat & low oil pressure engine protection	■

Hydraulic

Variable axial piston main pump	■
Full electric hydraulics	■
Hydraulic transmission	■
Adjustable auxiliary flow	■

Electrical

Alternator – 12 V, 100 A	■
12 V battery, 725 CCA @ 0° F (-18° C)	■
Additional LED lighting	■
Rotating beacon	■
Hour meter	■
Laptop service port	■
Self-diagnostics system	■

Undercarriage

Idler trap strings	■
Segmented sprocket	■
Double- and single-sided rollers	■
Oscillating undercarriage	■
GP guard	■
Full track guard	•
Adjustable/replaceable idler guide plate	■
Serrated tracks	■
Sealed and lubricated track (SALT)	■
Shoes, steel grouser	■

Cabin

Steel, all-weather & sound suppressed	■
ROPS/TOPS (ISO 12117-2:2008)	■
Front window and side window with wiper/washer	■
Rearview camera	■
8" Smart Touch display	■
Rear window defrost in-glass	■
Tinted safety glass	■
Lockable doors	■
Seat	■
- Air-suspension	■
- 2" (51 mm) seat belt	■
- Adjustable height & recline	■
Adjustable armrests	■
Air conditioner with heater	■
Mirrors	■
AM/FM stereo & Bluetooth®	■
Speakers (2)	■
Power socket, 12 V	■
Interior light	■
Storage for operator's manuals	■

Controls

Blade shake	■
Blade float	■
2D grade control system	■
ECO mode	■
Blade control lever	■
Engine speed control dial	■
Switches, console-mounted	■
- Starter switch (key)	■
- Heater/AC control panel	■
- Boom swing switch	■
- Rotating beacon (if equipped)	■
- 12 V power socket & USB charger	■
Keypad buttons	■
- Overload warning	■
- Travel/swing alarm	■
- Light	■
- Work lights	■
- Wiper & washer	■
- Auto idle	■
Emergency stop switch	■

Display Monitor & Warnings

Buzzer	■
- Engine oil pressure	■
- Coolant temperature	■
Touch screen display monitor	■
- Digital clock	■
- Menu select button	■
- Back button	■
- Fuel gauge	■
- Engine coolant temperature	■
- Hydraulic oil temperature	■
- Mode	■
- Tachometer	■
- Operating mode/flow setting selector	■
Indicator lights	■
- Air filter restriction indicator	■
- Engine check warning light	■
- Hydraulic oil warning	■
- Fuel warning	■
- Auto idle indicator	■
- Auxiliary flow mode indicator	■
- Engine oil pressure light with audible alarm	■
- Preheat (cold start assist) indicator	■
- Two-speed travel indicator light	■
Travel alarm	■

Other

Centralized lubrication	■
Parallel ripper	•
Cab-raise	■
Reversing fan	■
Reversible cutting edge	■
Forestry guard	•
Dozer blade	■
Drawbar	■
Manuals	■
- Operation	■
- AEM safety manual	■
Vandalism protection	■
- Lockable panels	■
- Lockable fluid fill points	■
MY DEVELON (telematics)	■

Features

- 2D grade control system
- 8-inch Smart Touch display
- Standard rearview camera
- LED lights

- Enhanced visibility with minimized front pillars, maximum glass and inline precleaner
- Front, rear and side wiper blades
- Reversible blade cutting edge



- Robust power and durability
- Optimized for more power output with reduced fuel consumption
- Operator presence switch
- Pressurized and sealed cab
- Tilting cab for easier maintenance

- Dual/single flange-type roller with multiple track guard options
- Ripper circuit
- Sprocket segments
- Sealed and lubricated track
- Reversing fan

Certain specification(s) are based on engineering calculations and are not actual measurements. Specification(s) are provided for comparison purposes only and are subject to change without notice. Specification(s) for your individual DEVELON equipment will vary based on normal variations in design, manufacturing, operating conditions, and other factors. Pictures of DEVELON units may show other than standard equipment.

Powered by Innovation

DEVELON

A brand of HD Hyundai Infracore.

na.develon-ce.com/dd130

DD130 Dozer Spec Sheet
Printed in the U.S.A.
23914_004_D080924

©2024 HD Hyundai Infracore. All rights reserved.